

Directional spool valves, direct operated, with solenoid actuation

Type WE

www: www.salushydraulics.pl
 e-mail: pl@salushydraulics.pl
 shop/sklep: www.salushydraulics.pl/sklep/

RE 23178
 Edition: 2013-06
 Replaces: 04.09



H7564

- ▶ Size 6
- ▶ Component series 6X
- ▶ Maximum operating pressure 350 bar [5076 psi]
- ▶ Maximum flow: 80 l/min [21 US gpm] – DC
60 l/min [15.8 US gpm] – AC



Features

- ▶ 4/3, 4/2 or 3/2 directional design
- ▶ High-power solenoid
- ▶ Porting pattern according to DIN 24340 form A
- ▶ Porting pattern according to ISO 4401-03-02-0-05 and NFPA T3.5.1 R2-2002 D03
- ▶ Wet-pin DC or AC solenoids with detachable coil
- ▶ Solenoid coil can be rotated by 90°
- ▶ The coil can be changed without having to open the pressure-tight chamber
- ▶ Electrical connection as individual or central connection
- ▶ Manual override, optional
- ▶ Spool position monitoring, optional

Contents

Features	1
Ordering code	2 ... 4
Mating connectors	4
Symbols	5
Function, section	6
Technical data	7, 8
Characteristic curves	9
Performance limits	10 ... 12
Dimensions	13 ... 18
Circuit breakers	19
More information	19

Ordering code

01	02	03	04	05	06	07	08	09	10	11	12	13	14	15	16
	WE	6		6X	/		E				/				*

01	3 main ports	3
	4 main ports	4
02	Directional valve	WE
03	Size 6	6
04	Symbols e.g. C, E, EA, EB, etc; for the possible version, see page 5	
05	Component series 60 to 69 (60 to 69: Unchanged installation and connection dimensions)	6X
06	With spring return	no code
	Without spring return	O
	Without spring return with detent	OF
07	High-power wet-pin solenoid with detachable coil	E
08	Direct voltage 24 V	G24
	AC voltage 230 V 50/60 Hz	W230
	AC voltage 120 V or 110 V 50/60 Hz	W110 W + voltage
	Direct voltage 205 V	G205
	DC solenoid with rectifier for AC voltage (not frequency-related; only available with plug-in connection with cover, see page 17)	W110R
	Connection to AC voltage mains via control with rectifier (see table below and page 4) ¹⁾ For further ordering codes for other voltages and frequencies, see page 8	
09	Without manual override	no code
	With concealed manual override (standard)	N9 ²⁾
	With manual override	N ²⁾
	With lockable manual override "mushroom button" (small)	N4 ²⁾
	With lockable manual override "mushroom button" (big)	N5 ^{2; 3)}
	With manual override "mushroom button" (big), not lockable	N6 ²⁾
	With lockable manual override "nut"	N7 ²⁾

Electrical connection

10	Individual connection	
	Without mating connector, with connector according to DIN EN 175301-803	K4 ⁴⁾
	Without mating connector, with connector AMP Junior-Timer	C4 ⁴⁾
	Without mating connector, with connector DT 04-2PA (Deutsch plug)	K40 ^{4; 7)}
	Without mating connector, 4-pole with connector M12x1 according to IEC 60947-5-2, integrated interference protection circuit and status LED	K72L ⁵⁾
	Without mating connector, 4-pole with connector M12x1 according to IEC 60947-5-2, integrated interference protection circuit and status LED (no connection pin 1 to pin 2)	K73L ⁵⁾
	Central connection	
	Cable entry at the cover, with indicator light	DL
	Central plug-in connection at the cover, with indicator light (without mating connector); connector according to DIN EN 175201-804	DK6L ⁶⁾
	For further electrical connections, see data sheet 08010	

AC voltage mains (admissible voltage tolerance ±10%)	Nominal voltage of the DC solenoid in case of operation with alternating voltage	Ordering code
110 V - 50/60 Hz	96 V	G96
230 V - 50/60 Hz	205 V	G205

Ordering code

01	02	03	04	05	06	07	08	09	10	11	12	13	14	15	16
	WE	6		6X	/		E				/				*

Spool position monitoring

11	Without position switch	no code
	- Inductive position switch type QM	
	Monitored spool position "a"	QMAG24
	Monitored spool position "b"	QMBG24
	Monitored rest position	QM0G24
	- Inductive position switch type QR	
	Monitored rest position	QR0G24S
	Monitored spool position "a" and "b"	QRABG24E
	- Inductive position switch type QL	
	Monitored spool position "a"	QLAG24
	Monitored spool position "b"	QLBG24
	- Inductive proximity sensor type QS	
	Monitored spool position "a"	QSAG24W
	Monitored spool position "b"	QSBG24W
	Monitored spool position "0"	QS0G24W
	Monitored spool position "0" and "a"	QS0AG24W
	Monitored spool position "0" and "b"	QS0BG24W
	Monitored spool position "a" and "b"	QSABG24W
	For more information, see data sheet 24830	

12	Without throttle insert	no code
	With throttle insert see table:	
	Port	Throttle Ø in mm [inch]
		0.8 [0.031] 1.0 [0.039] 1.2 [0.047]
	P	= B08 = B10 = B12
	A	= H08 = H10 = H12
	B	= R08 = R10 = R12
	A and B	= N08 = N10 = N12
	T	= X08 = X10 = X12
	Use with flows which exceed the performance limit of the valve (see page 6).	

Clamping length

13	42 mm [1.65 inch] (standard)	no code
	22 mm [0.87 inch]	Z

Seal material

14	NBR seals	no code
	FKM seals	V
	Attention: Observe compatibility of seals with hydraulic fluid used! (Other seals upon request)	

15	Without locating hole	no code
	With locating hole	/60^{B)}
	With locating hole and locking pin ISO 8752-3x8-St	/62

16	Further details in the plain text	
----	-----------------------------------	--

Explanation of the footnotes see page 4.

Preferred types and standard units are contained in the EPS (standard price list).

Ordering code

- 1) Only for version "individual connection"
- 2) The manual override cannot be allocated a safety function. The manual override units may only be used up to a tank pressure of 50 bar.
- 3) With tank pressures above 50 bar, it cannot be guaranteed that the valve remains in the position switched by the manual override "N5".
- 4) Mating connectors, separate order, see below and data sheet 08006
- 5) Only version "G24", see data sheet 08010
- 6) Mating connector, separate order, material no. **R900005538**
- 7) Only possible in connection with the symbols G, J, D and E as well a reduced performance limit.
- 8) Locking pin ISO 8752-3x8-St, material no. **R900005694** (separate order)

Mating connectors according to DIN EN 175301-803

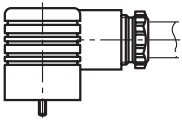
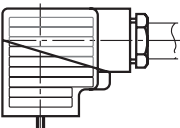
For details and more mating connectors, see data sheet 08006							
Port	Valve side	Color	Material number				
			Without circuitry	With indicator light 12 ... 240 V	With indicator light and rectifier 12 ... 240 V	With rectifier 12 ... 240 V	With indicator light and Zener diode suppression circuit 24 V
M16 x 1.5	a	Gray	R901017010	-	-	-	-
	b	Black	R901017011	-	-	-	-
	a/b	Black	-	R901017022	R901017029	R901017025	R901017026
1/2" NPT (Pg 16)	a	Red/ brown	R900004823	-	-	-	-
	b	Black	R900011039	-	-	-	-
	a/b	Black	-	R900057453	R900057455	R900842566	-

Symbols

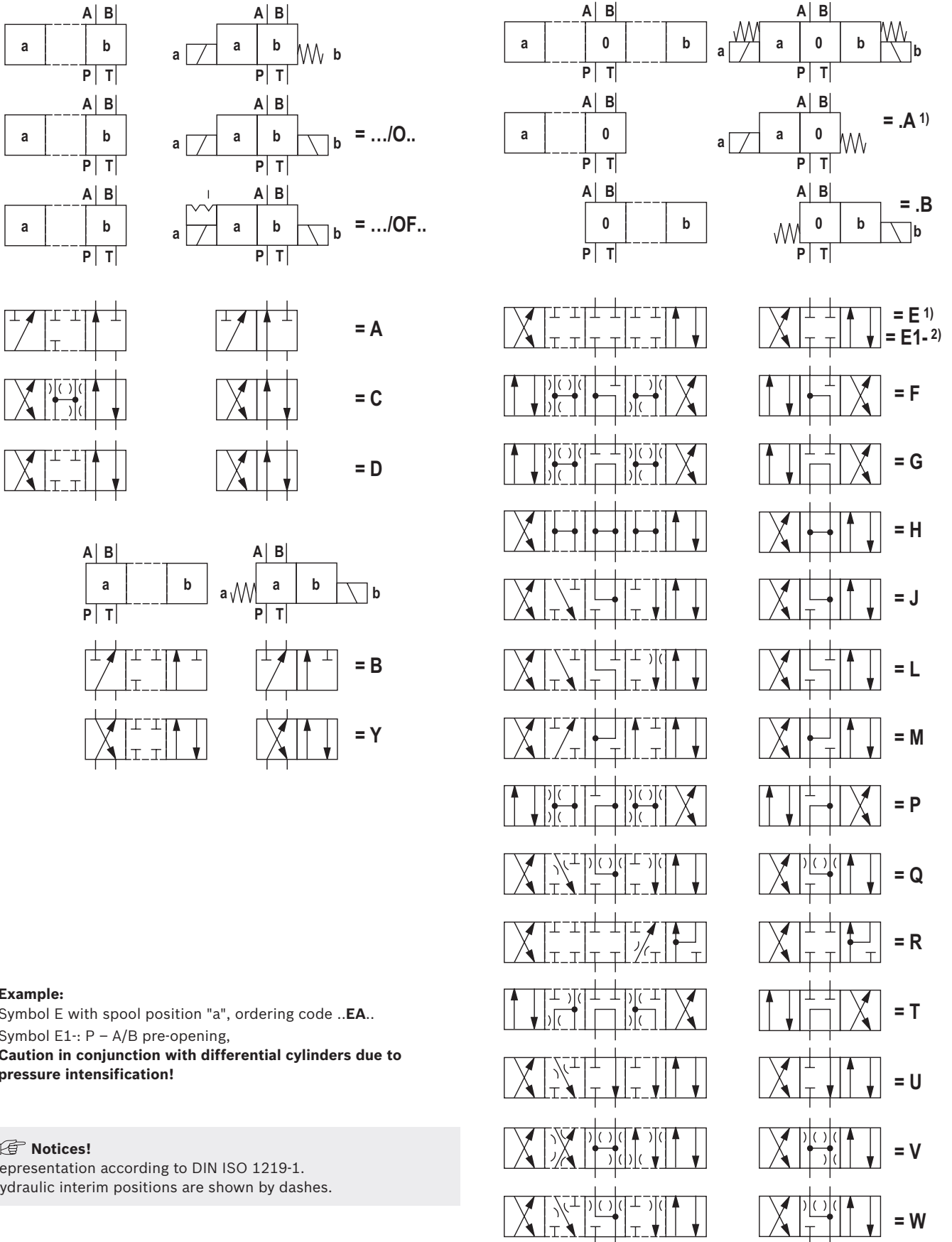

1) **Example:**
Symbol E with spool position "a", ordering code ..EA..

2) Symbol E1-: P – A/B pre-opening,
Caution in conjunction with differential cylinders due to pressure intensification!

Notices!

Representation according to DIN ISO 1219-1.
Hydraulic interim positions are shown by dashes.

Function, section

Directional valves of type WE are solenoid operated directional spool valves. They control the start, stop and direction of a flow.

The directional valves basically consist of the housing (1), one or two electronic solenoids (2), the control spool (3), and one or two return springs (4).

In the de-energized condition, the control spool (3) is held in the central position or in the initial position by the return springs (4) (except for impulse spools). The control spool (3) is actuated by wet-pin electronic solenoids (2).

To ensure proper functioning, care must be taken that the pressure chamber of the electronic solenoid is filled with oil.

The force of the electronic solenoid (2) acts via the plunger (5) on the control spool (3) and pushes the latter from its rest position to the required end position. This enables the necessary direction of flow from P to A and B to T or P to B and A to T.

When the electronic solenoid (2) is de-energized, the return spring (4) pushes the control spool (3) back to its rest position.

An optional manual override (6) allows the control spool (3) to be moved without solenoid energization.

Without spring return "O" (only possible with symbols A, C and D)

This version is a directional valve with 2 spool positions and 2 electronic solenoids **without** detent. The valve without spring return at the control spool (3) has no defined basic position in the de-energized condition.

Without spring return with "OF" detent (only possible with symbols A, C and D)

This version is a directional valve with 2 spool positions and 2 electronic solenoids **with** detent. The detents are used to fix the control spool (3) in the relevant spool position. During operation, continuous application of current to the electronic solenoid can thus be omitted which contributes to energy-efficient operation.

Notices!

Pressure peaks in the tank line to two or several valves can result in unintended control spool movements in the case of valves with detent! We therefore recommend that separate return lines be provided or a check valve installed in the tank line.

Due to the design principle, internal leakage is inherent to the valves, which may increase over the life cycle.

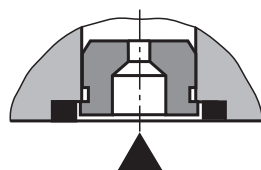
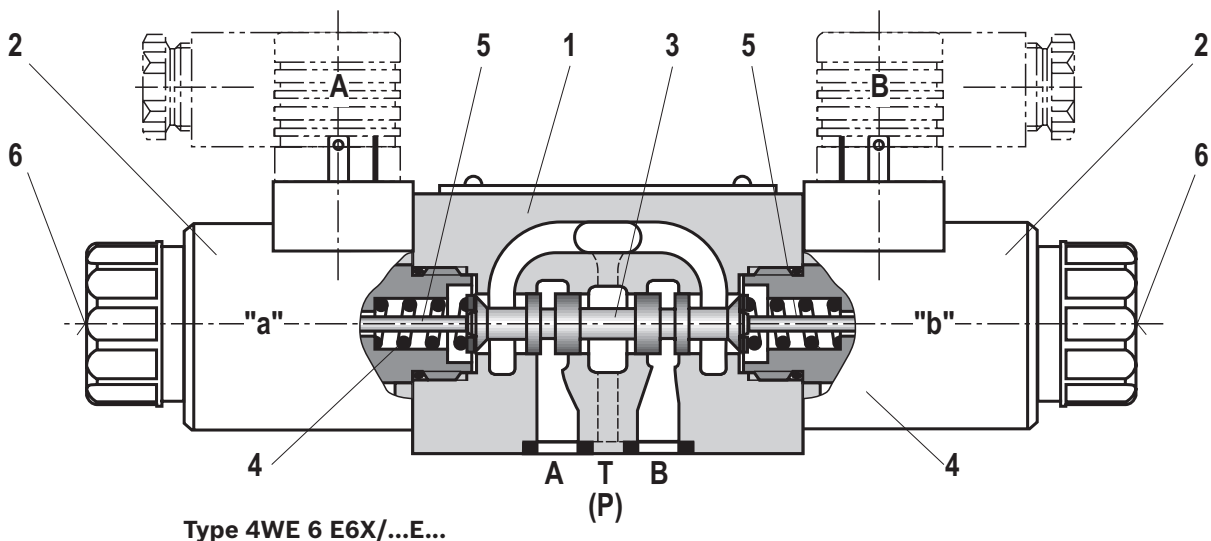

Throttle insert

The use of the throttle insert is required when, due to prevailing operating conditions, flows occur during the switching processes which exceed the performance limit of the valve.

Technical data

(for applications outside these parameters, please consult us!)

general			
Weight	- Valve with one solenoid	kg [lbs]	1.45 [3.2]
	- Valve with two solenoids	kg [lbs]	1.95 [4.3]
Installation position			Any
Ambient temperature range		°C [°F]	-30 ... +50 [-22 ... +122] (NBR seals) -20 ... +50 [-4 ... +122] (FKM seals)
MTTF _d values according to EN ISO 13849		Years	150 (for further details see data sheet 08012)

hydraulic			
Maximum operating pressure	- Ports A, B, P	bar [psi]	350 [5076]
	- Port T	bar [psi]	210 [3050] (DC); 160 [2320] (AC) With symbols A and B, port T must be used as leakage oil connection.
Maximum flow		l/min [USgpm]	80 [21] (DC); 60 [15.8] (AC)
Flow cross-section (spool position 0)	- Symbol Q	mm ²	Approx. 6% of nominal cross-section
	- Symbol W	mm ²	Approx. 3% of nominal cross-section
Hydraulic fluid			See table below
Hydraulic fluid temperature range		°C [°F]	-30 ... +80 [-22 ... +176] (NBR seals) -15 ... +80 [-4 ... +176] (FKM seals)
Viscosity range		mm ² /s [cSt]	2.8 ... 500 [35 ... 2320]
Maximum admissible degree of contamination of the hydraulic fluid - cleanliness class according to ISO 4406 (c)			Class 20/18/15 ¹⁾

Hydraulic fluid	Classification	Suitable sealing materials	Standards
Mineral oils	HL, HLP, HLPD, HVLP, HVLPD	NBR, FKM	DIN 51524
Bio-degradable	- insoluble in water	HETG	VDMA 24568
		HEES	
	- soluble in water	HEPG	VDMA 24568
Flame-resistant	- water-free	HFDU, HFDR	ISO 12922
	- containing water	HFC (Fuchs Hydrotherm 46M, Petrofer Ultra Safe 620)	NBR ISO 12922



Important information on hydraulic fluids!

- ▶ For more information and data on the use of other hydraulic fluids, refer to data sheet 90220 or contact us!
- ▶ There may be limitations regarding the technical valve data (temperature, pressure range, life cycle, maintenance intervals, etc.)!
- ▶ The flash point of the hydraulic fluid used must be 40 K higher than the maximum solenoid surface temperature.
- ▶ **Flame-resistant – containing water:**
 - Maximum pressure difference per control edge 50 bar
 - Pressure pre-loading at the tank port >20% of the pressure differential, otherwise increased cavitation
 - Life cycle as compared to operation with mineral oil HL, HLP 50 to 100%
- ▶ **Bio-degradable:** When using bio-degradable hydraulic fluids that are simultaneously zinc-soluble, zinc may accumulate in the fluid (per pole tube 700 mg zinc).

¹⁾ The cleanliness classes specified for the components must be adhered to in hydraulic systems. Effective filtration prevents faults and at the same time increases the life cycle of the components. For maintenance requirements of the hydraulic fluid and contamination limit values, see data sheet 07300. For the selection of the filters, see www.boschrexroth.com/filter.

Technical data

(for applications outside these parameters, please consult us!)

electric			
Voltage type		Direct voltage	Alternating voltage 50/60 Hz
Available voltages ²⁾ (For ordering codes for AC voltage solenoids, see below)	V	12, 24, 96, 205	110, 230
Voltage tolerance (nominal voltage)	%	±10	
Power consumption	W	30	–
Holding power	VA	–	50
Switch-on power	VA	–	220
Duty cycle	%	100	
Switching time according to ISO 6403 ³⁾	– ON	ms	25 ... 45
	– OFF	ms	10 ... 25
Maximum switching frequency	1/h	15000	7200
Maximum surface temperature of the coil ⁴⁾	°C [°F]	120 [248]	180 [356]
Protection class according to DIN EN 60529	– With connector "K4", "K72L", "K73L"	IP 65 (with mating connector mounted and locked)	
	– With connector "C4"	IP 66A (with mating connector mounted and locked)	
	– With connector "K40"	IP 69K (with mating connector mounted and locked)	

2) Special voltages available upon request

3) The switching times were determined at a hydraulic fluid temperature of 40 °C [104 °F] and a viscosity of 46 cSt. Deviating hydraulic fluid temperatures can result in different switching times! Switching times change depending on operating time and application conditions.

4) Due to the temperatures occurring at the surfaces of the solenoid coils, the standards ISO13732-1 and ISO 4413 need to be adhered to!

The specified surface temperature in AC solenoids is valid for the faultless operation. In case of error (e.g. blocking of the control spool), the surface temperature may rise to above 180 °C [356 °F]. Thus, the system must be checked for possible dangers considering the flash point (see page 7).

As fuse protection, circuit breakers (see table on page 19) must be used, unless the creation of an ignitable atmosphere can be excluded in a different way. Thus, the surface temperature can – in case of error – be limited to maximally 220 °C [428 °F]. The tripping current must lie within a time interval of 0.6 s with 8 to 10 times the nominal power supply. (tripping characteristics "K").

The necessary non-tripping current of the fuse must not fall below the value I_1 (see table on page 19). The maximum tripping current of the fuse must not exceed the value I_2 (see table on page 19).

The temperature dependence of the tripping behavior of the circuit breakers has to be considered according to the manufacturer's specifications.

Notices!

- ▶ The actuation of the manual override is only possible up to a tank pressure of approx. 50 bar [725 psi]. Avoid damage to the bore of the manual override! (Special tool for the operation, separate order, material no. **R900024943**). When the manual override is blocked, actuation of the opposite solenoid must be ruled out!
- ▶ The simultaneous actuation of 2 solenoids of one valve must be ruled out!

Notice!

AC solenoids can be used for 2 or 3 mains; e.g. solenoid type **W110** for:
110 V, 50 Hz; 110 V, 60 Hz; 120 V, 60 Hz

Ordering code	Mains
W110	110 V, 50 Hz
	110 V, 60 Hz
	120 V, 60 Hz
W230	230 V, 50 Hz
	230 V, 60 Hz

When establishing the electrical connection, the protective earthing conductor (PE \perp) has to be connected correctly.

Characteristic curves

(measured with HLP46, $\vartheta_{oil} = 40 \pm 5 \text{ }^\circ\text{C}$ [$104 \pm 9 \text{ }^\circ\text{F}$])

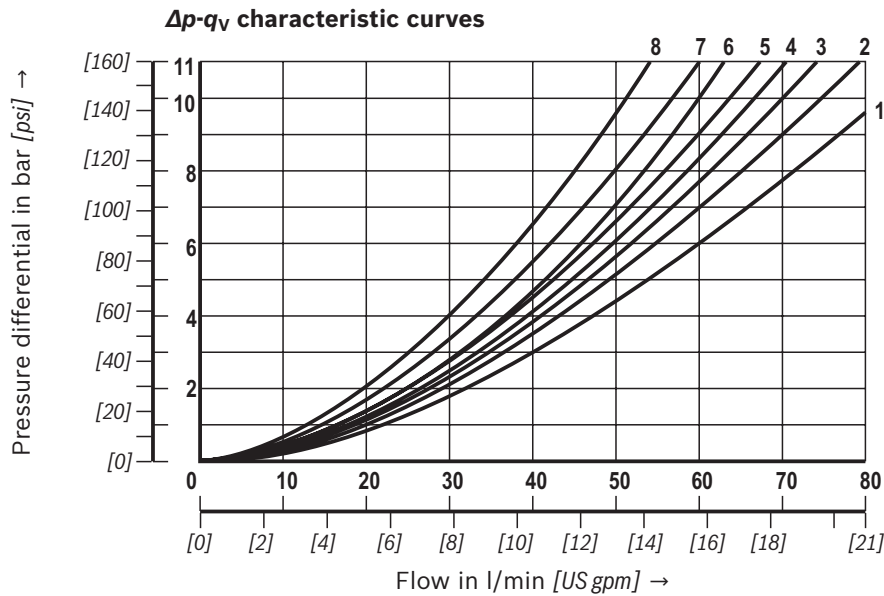

- 7 Symbol "R" in spool position B - A
- 8 Symbol "G" and "T" in central position P - T
- 9 Symbol "H" in central position P - T

Symbol	Direction of flow			
	P - A	P - B	A - T	B - T
A; B	5	5	-	-
C	3	3	5	3
D; Y	6	6	5	5
E	5	5	3	3
F	3	5	3	3
T	8	8	4	4
H	2	1	2	2
J; Q	3	3	2	3
L	5	5	1	4
M	2	1	5	5
P	5	3	3	3
R	6	6	1	-
V	3	2	3	3
W	3	3	2	2
U	5	5	4	1
G	7	7	4	4

Performance limits

(measured with HLP46, $\vartheta_{oil} = 40 \pm 5 \text{ }^\circ\text{C} [104 \pm 9 \text{ }^\circ\text{F}]$)

Notice!

The specified performance limits are valid for operation with two directions of flow (e.g. from P to A and simultaneous return flow from B to T).

Due to the flow forces acting within the valves, the admissible performance limit may be considerably lower

with only one direction of flow (e.g. from P to A while port B is blocked).

In such cases of application, please consult us!

The performance limit was determined when the solenoids were at operating temperature, at 10% under-voltage and without tank preloading.

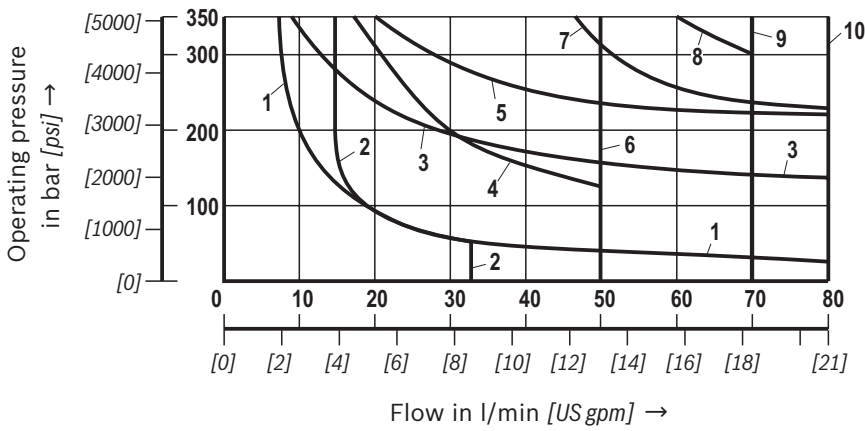

DC solenoid	
Characteristic curve	Symbol
1	A; B ¹⁾
2	V
3	A; B
4	F; P
5	J
6	G; H; T
7	A/O; A/OF; L; U
8	C; D; Y
9	M
10	E; E1- ²⁾ ; R ³⁾ ; C/O; C/OF; D/O; D/OF; Q; W

Solenoid voltage (DC solenoid)

12; 24; 48; 96; 125; 205 V

(other voltages, see page 11)

1) With manual override

2) P – A/B pre-opening

3) Return flow from actuator to tank

Performance limits

(measured with HLP46, $\vartheta_{oil} = 40 \pm 5 \text{ }^\circ\text{C}$ [$104 \pm 9 \text{ }^\circ\text{F}$])

See notice on page 10.

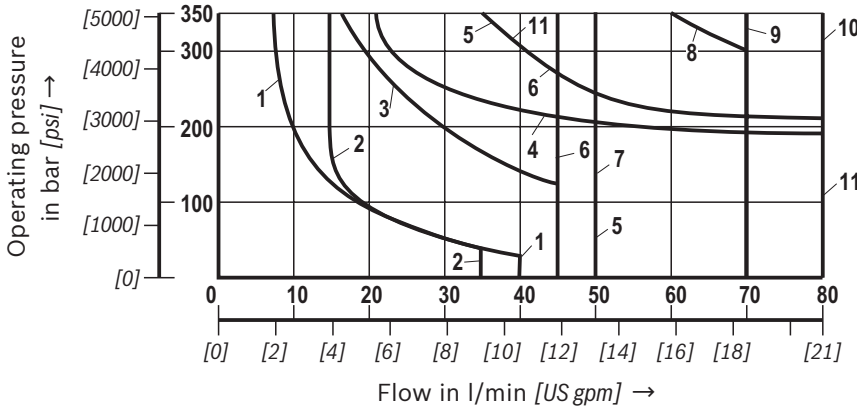

Solenoid voltage (DC solenoid)
110; 180 V

DC solenoid	
Characteristic curve	Symbol
1	A; B
2	V
3	F; P
4	J; L; U
5	G
6	T
7	H
8	D; C
9	M
10	C/O; C/OF; D/O; D/OF; E; E1-; R, Q; W
11	A/O; A/OF

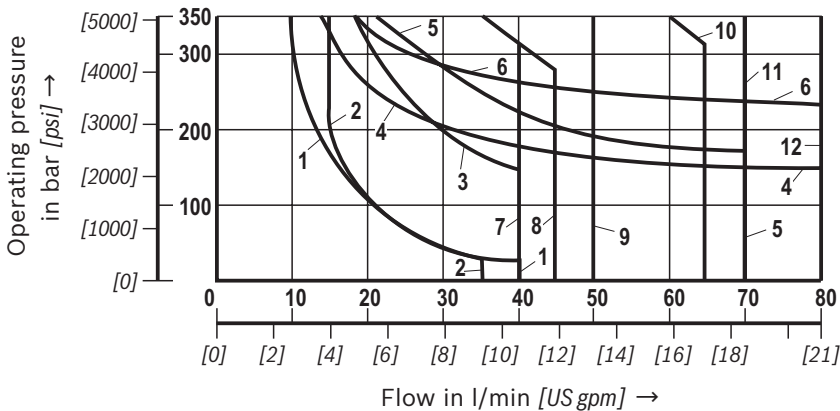

Solenoid voltage (DC solenoid)
42; 80; 220 V

DC solenoid	
Characteristic curve	Symbol
1	A; B
2	V
3	F; P
4	J; L; U
5	A/O; A/OF
6	E
7	T
8	G
9	H
10	D; C
11	M
12	C/O; C/OF; D/O; D/OF; E1-; R, Q; W

Performance limits

(measured with HLP46, $\vartheta_{oil} = 40 \pm 5 \text{ }^\circ\text{C} [104 \pm 9 \text{ }^\circ\text{F}]$)

See notice on page 10.

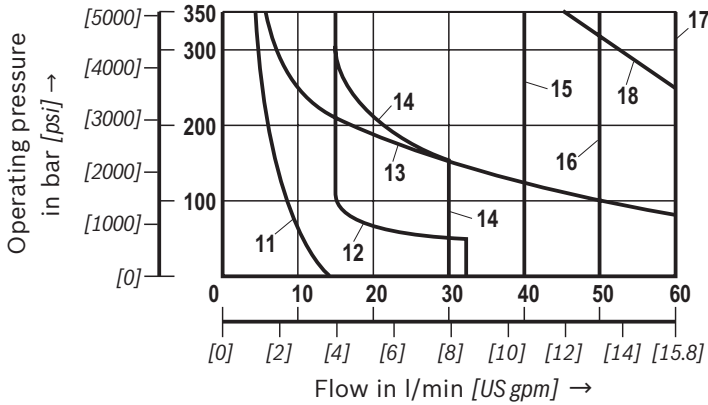

AC solenoid – 50 Hz	
Characteristic curve	Symbol
11	A; B ¹⁾
12	V
13	A; B
14	F; P
15	G; T
16	H
17	A/O; A/OF; C/O; C/OF; D/O; D/OF; E; E1 ⁻²⁾ ; J; L; M; Q; R ³⁾ ; U; W
18	C; D; Y

Solenoid voltage (AC solenoid)	
W110	110 V; 50 Hz 120 V; 60 Hz
W230	230 V; 50 Hz

- 1) With manual override
- 2) P – A/B pre-opening
- 3) Return flow from actuator to tank

(other voltages upon request)

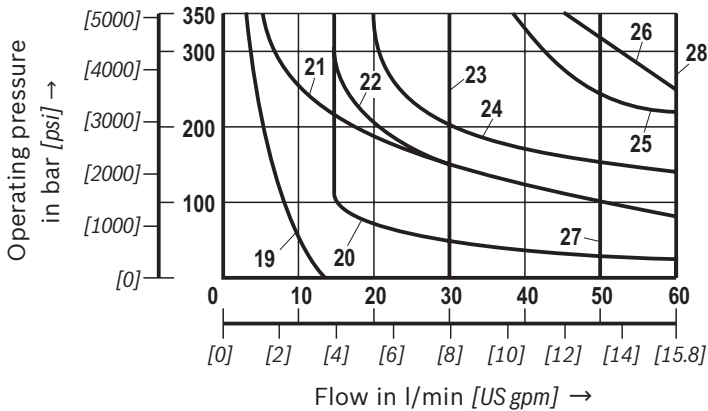

AC solenoid – 60 Hz	
Characteristic curve	Symbol
19	A; B ¹⁾
20	V
21	A; B
22	F; P
23	G; T
24	J; L; U
25	A/O; A/OF; Q; W
26	C; D; Y
27	H
28	C/O; C/OF; D/O; D/OF; E; E1 ⁻²⁾ ; M; R ³⁾

Solenoid voltage (AC solenoid)	
W110	110 V; 60 Hz
W230	230 V; 60 Hz

- 1) With manual override
- 2) P – A/B pre-opening
- 3) Return flow from actuator to tank

(other voltages upon request)

Dimensions: Valve with DC solenoid – **Individual connection**
(dimensions in mm [inch])

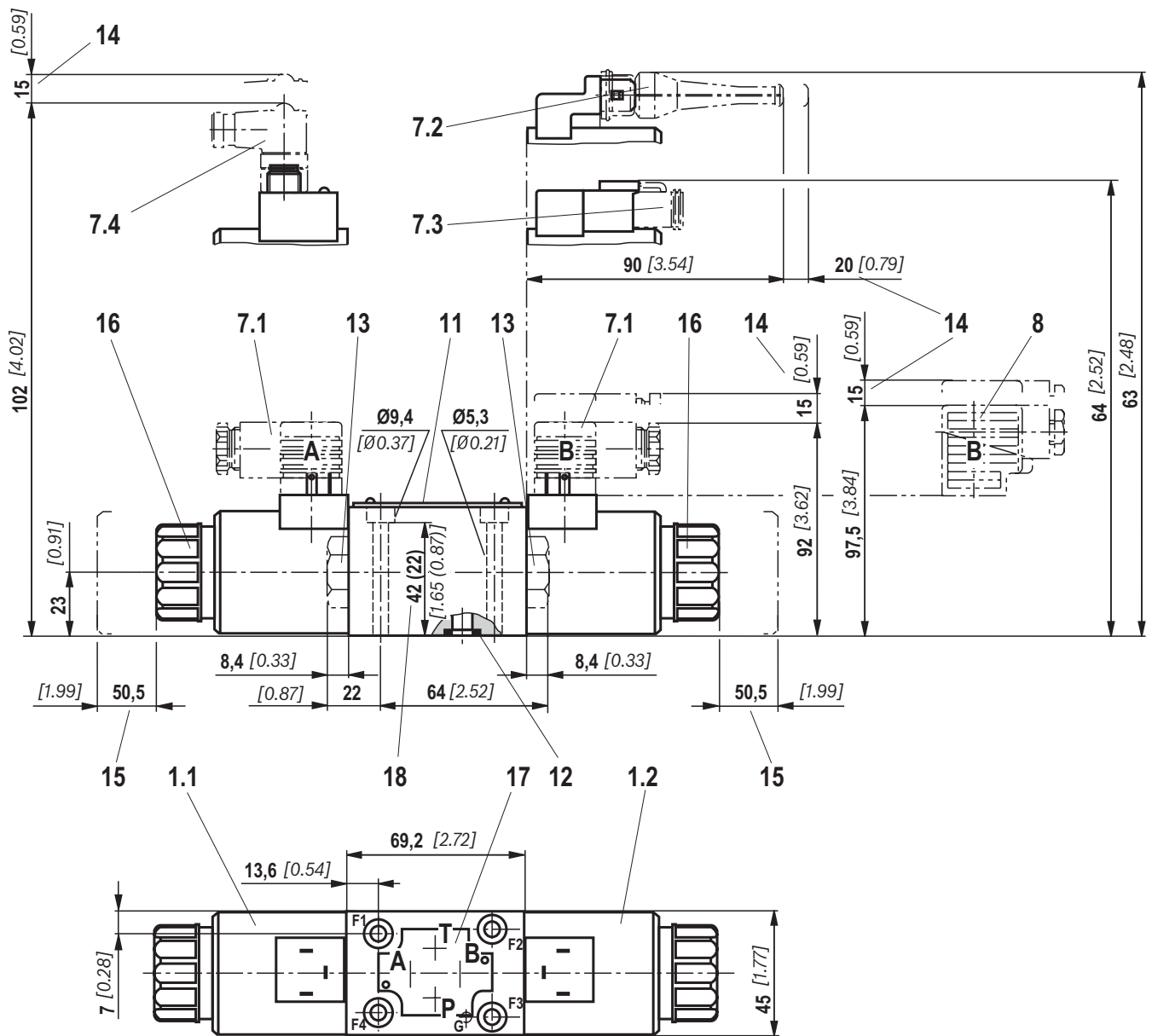

Dimensions for manual overrides see page 15.
Item explanations, valve mounting screws and subplates
see page 18.

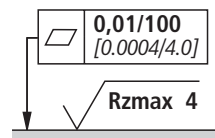

Required surface quality of the valve contact surface

Dimensions: Valve with DC solenoid – **Central connection**
(dimensions in mm [inch])

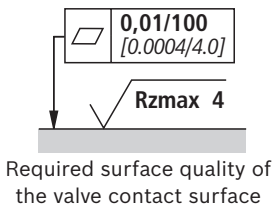
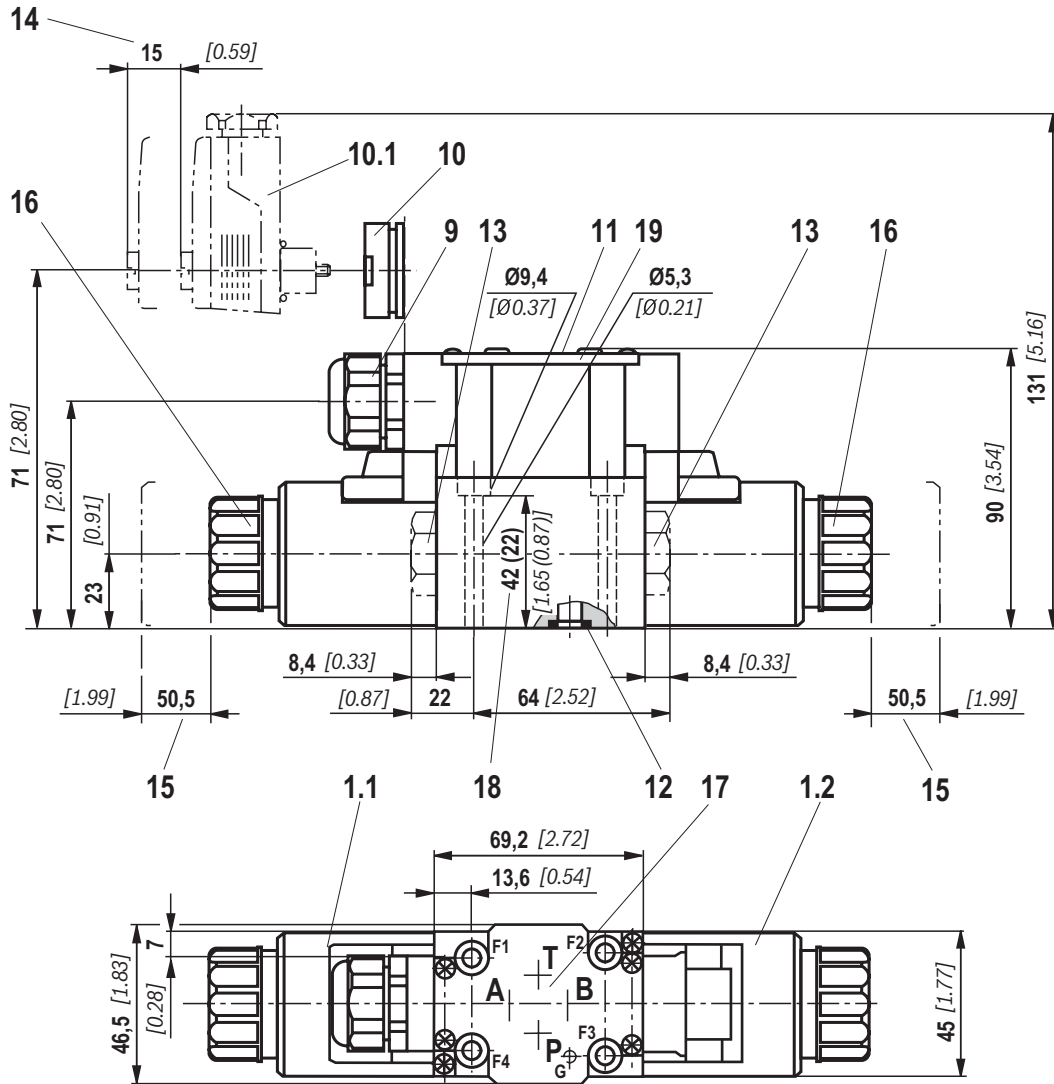

Terminal assignment with central connection:

- ▶ **1 solenoid:**
Always connect the solenoid to terminals 1 and 2, the protective earthing connector to terminal ⊕ PE
- ▶ **2 solenoids:**
Always connect solenoid "a" to terminals 1 and 2, solenoid "b" to terminals 3 and 4, the protective earthing conductor to terminal ⊕ PE

Dimensions for manual overrides see page 15.

Item explanations, valve mounting screws and subplates see page 18.

Dimensions: Valve with DC solenoid – Manual overrides
(dimensions in mm [inch])

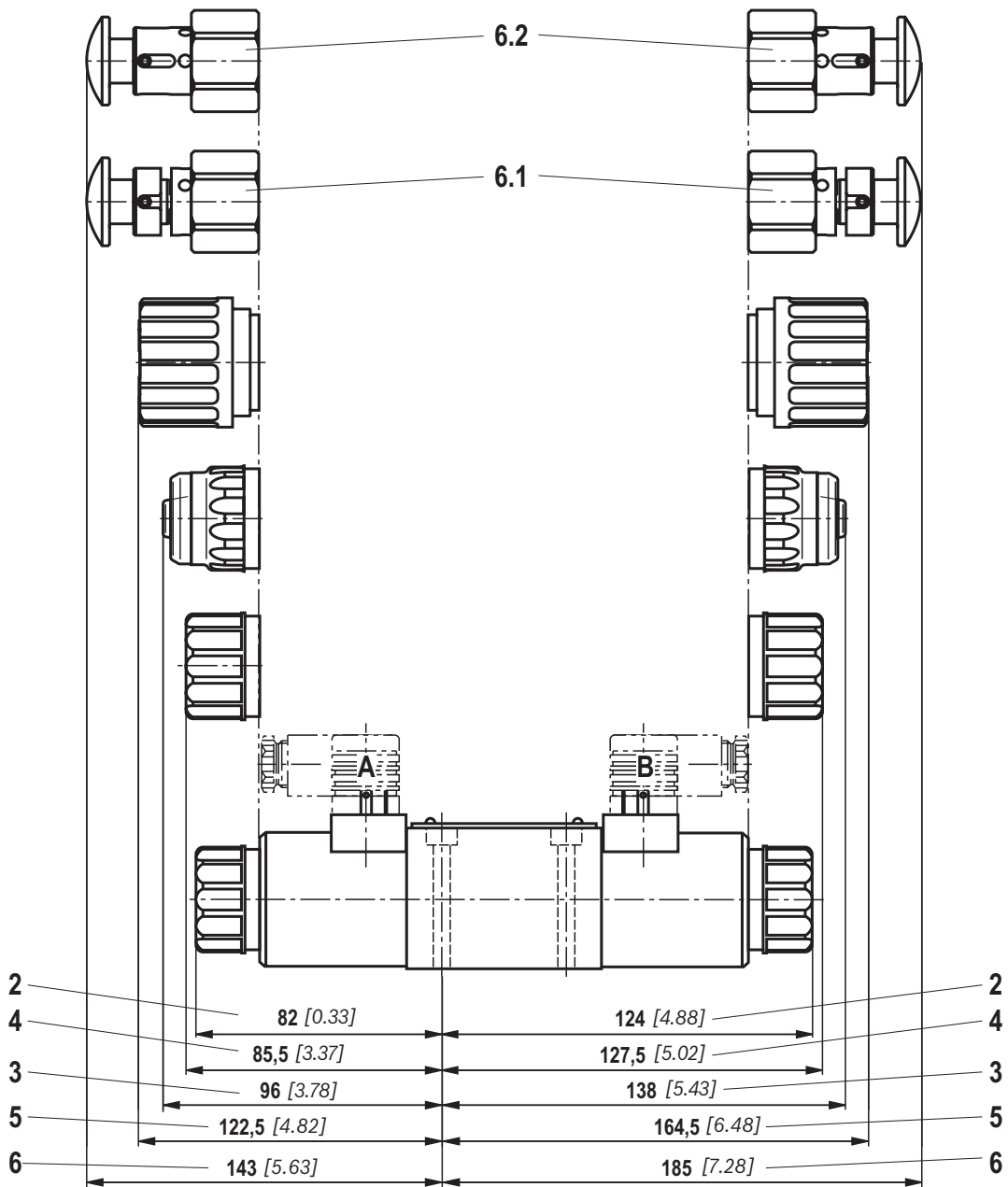

Item explanations, valve mounting screws and subplates
see page 18.

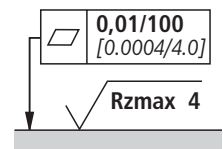

Required surface quality of the valve contact surface

Dimensions: Valve with AC solenoid – **Individual connection**
(dimensions in mm [inch])

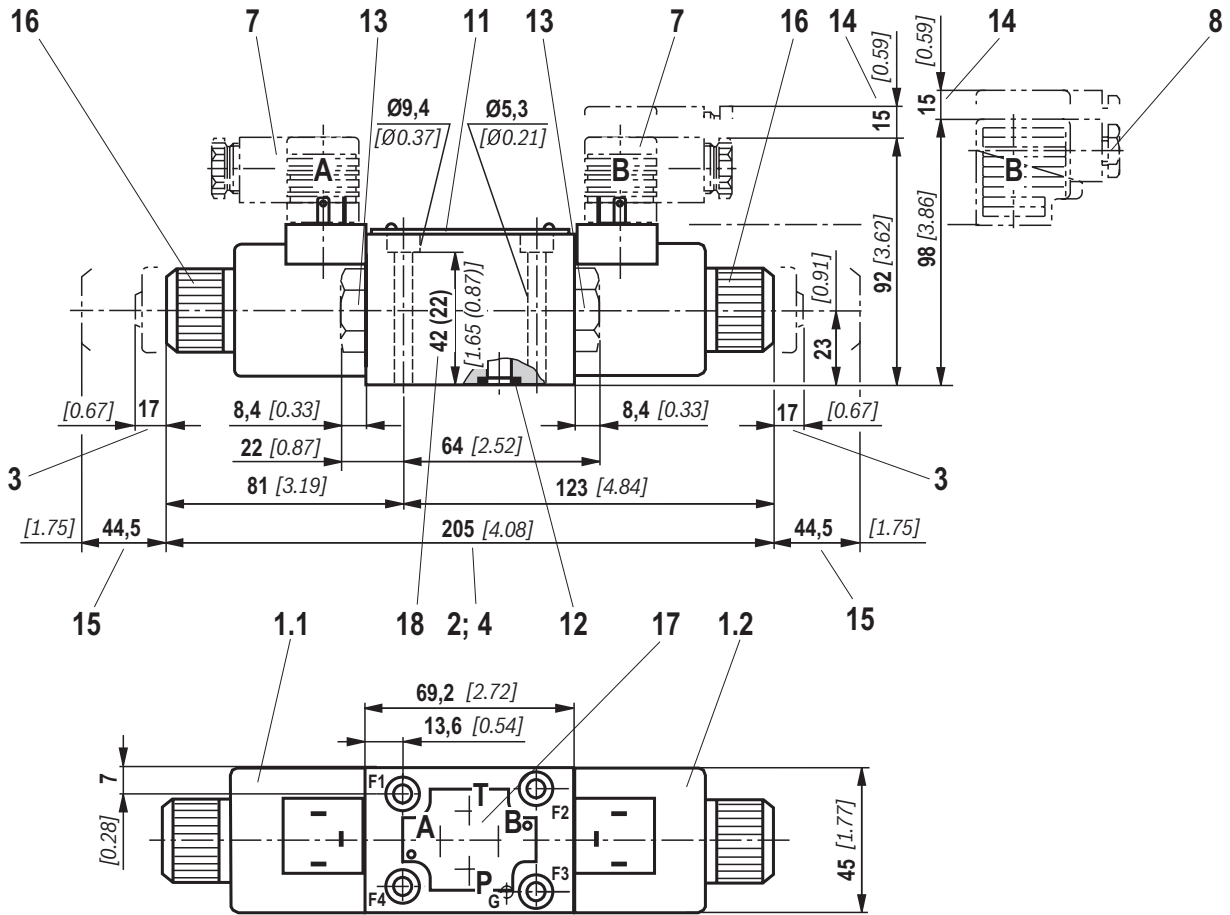

Required surface quality of the valve contact surface

Item explanations, valve mounting screws and subplates
see page 18.

Dimensions: Valve with AC solenoid – **Central connection**
(dimensions in mm [inch])

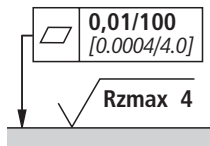
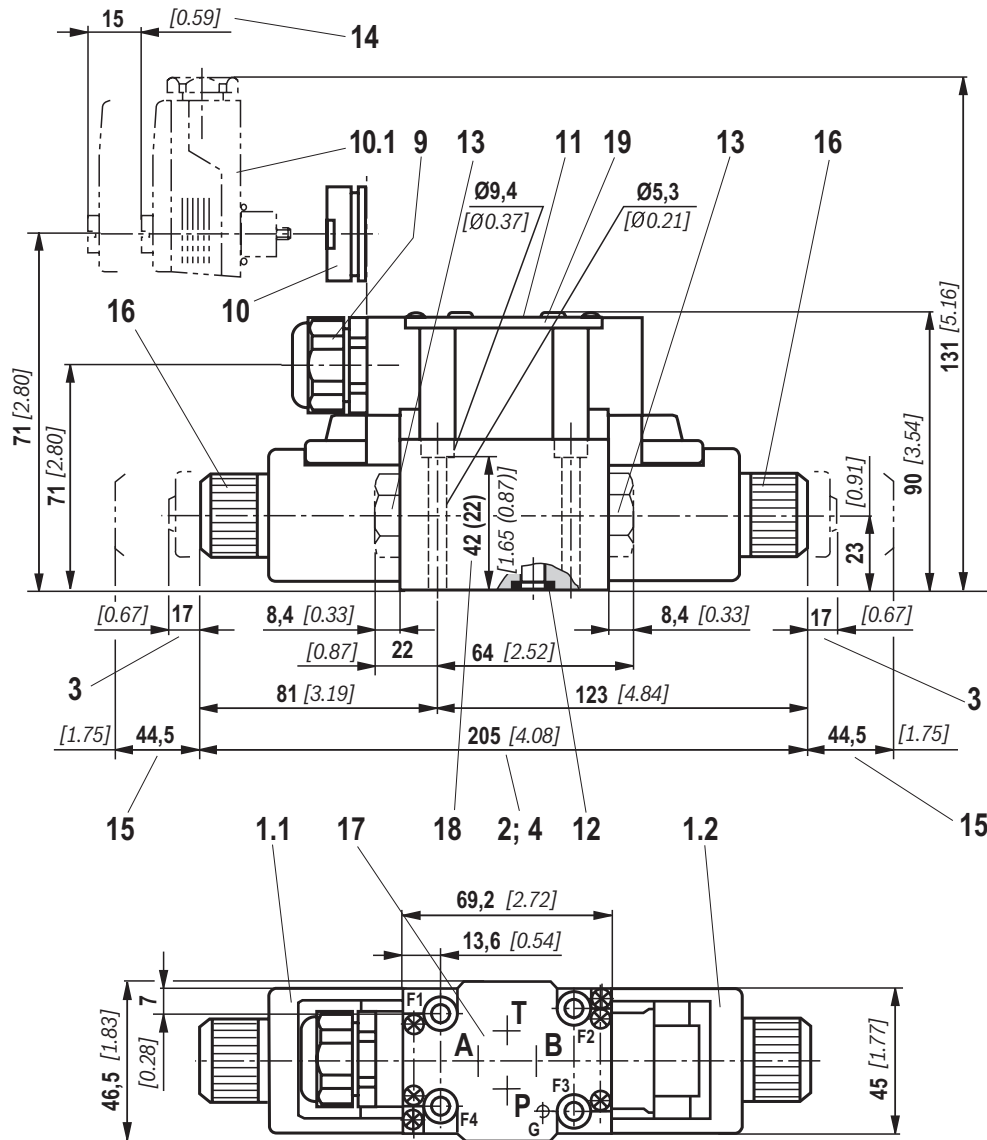

Required surface quality of the valve contact surface

Terminal assignment with central connection:

► **1 solenoid:**

Always connect the solenoid to terminals 1 and 2, the protective earthing connector to terminal \oplus PE

► **2 solenoids:**

Always connect solenoid "a" to terminals 1 and 2, solenoid "b" to terminals 3 and 4, the protective earthing to terminal \oplus PE

Item explanations, valve mounting screws and subplates
see page 18.

Dimensions

- 1.1 Solenoid "a"
- 1.2 Solenoid "b"
 - 2 Dimension for solenoid **with concealed** manual override "N9" (standard)
 - 3 Dimension for solenoid **with** manual override "N"
 - 4 Dimension for solenoid **without** manual override
 - 5 Dimension for solenoid **with** manual override "N7"
 - 6 Dimension for solenoid **with** manual override "N5" and "N6"
- 6.1 Manual override "N5"
- 6.2 Manual override "N6"
- 7.1 Mating connector **without** circuitry for connector "K4" (separate order, see page 4 and data sheet 08006)
- 7.2 Mating connector (AMP Junior Timer) with connector "C4" (separate order, see data sheet 08006)
- 7.3 Mating connector DT 04-2PA (Deutsch plug) with connector "K40" (separate order, see data sheet 08006)
- 7.4 Mating connector angled with M12x1 plug-in connection with status LED "K72L" (separate order, see data sheet 08006)
 - 8 Mating connector **with** circuitry for connector "K4" (separate order, see page 4 and data sheet 08006)
- 9 Cable gland Pg 16 [1/2" NPT] "DL"
- 10 Central plug-in connection "DKL"
- 10.1 Angled socket (red, separate order)
Material no. **R900005538**
- 11 Name plate
- 12 Identical seal rings for ports A, B, P, T
 -  **Notice!** The ports are clearly determined according to their tasks and must not be arbitrarily interchanged or closed.
- 13 Plug screw for valves with one solenoid
- 14 Space required to remove the mating connector/angled socket
- 15 Space required to remove the coil
- 16 Mounting nut, tightening torque $M_A = 4^{+1} \text{ Nm } [2.95^{+0.74} \text{ ft-lbs}]$
- 17 Porting pattern according to DIN 24340 form A (**without** locating hole), or ISO 4401-03-02-0-05 and NFPA T3.5.1 R2-2002 D03 (**with** locating hole for locking pin ISO 8752-3x8-St, material no. **R900005694**, separate order)
- 18 Alternative clamping length (): 22 mm [0.87 inch]
- 19 Cover
 - Attention!**
The valve may only be operated with properly mounted cover.

Subplates according to data sheet 45052

(separate order)	
(without locating hole)	G 341/01 (G1/4) G 342/01 (G3/8) G 502/01 (G1/2)
(with locating hole)	G 341/60 (G1/4) G 342/60 (G3/8) G 502/60 (G1/2) G 341/12 (SAE-6) ¹⁾ G 342/12 (SAE-8) ¹⁾ G 502/12 (SAE-10) ¹⁾

¹⁾ Upon request

Valve mounting screws (separate order)

- ▶ Clamping length 42 mm:
4 metric hexagon socket head cap screws ISO 4762 - M5 x 50 - 10.9-fIZn-240h-L
(friction coefficient $\mu_{\text{total}} = 0.09$ to 0.14);
tightening torque $M_A = 7 \text{ Nm } [5.2 \text{ ft-lbs}] \pm 10\%$,
material no. **R913000064**
or
4 hexagon socket head cap screws ISO 4762 - M5 x 50 - 10.9²⁾
(friction coefficient $\mu_{\text{total}} = 0.12$ to 0.17);
tightening torque $M_A = 8.1 \text{ Nm } [6 \text{ ft-lbs}] \pm 10\%$

- 4 hexagon socket head cap screws UNC 10-24 UNC x 2" ASTM-A574**
(friction coefficient $\mu_{\text{total}} = 0.19$ bis 0.24);
tightening torque $M_A = 11 \text{ Nm } [8.2 \text{ ft-lbs}] \pm 15\%$,
(friction coefficient $\mu_{\text{total}} = 0.12$ to 0.17);
tightening torque $M_A = 8 \text{ Nm } [5.9 \text{ ft-lbs}] \pm 10\%$,
material no. **R978800693**

- ▶ Clamping length 22 mm:
4 metric hexagon socket head cap screws ISO 4762 - M5 x 30 - 10.9-fIZn-240h-L
(friction coefficient $\mu_{\text{total}} = 0.09$ to 0.14);
tightening torque $M_A = 7 \text{ Nm } [5.2 \text{ ft-lbs}] \pm 10\%$,
material no. **R913000316**
or
4 hexagon socket head cap screws ISO 4762 - M5 x 30 - 10.9²⁾
(friction coefficient $\mu_{\text{total}} = 0.12$ to 0.17);
tightening torque $M_A = 8.1 \text{ Nm } [6 \text{ ft-lbs}] \pm 10\%$

- 4 hexagon socket head cap screws UNC 10-24 UNC x 1 1/4"**
(friction coefficient $\mu_{\text{total}} = 0.19$ to 0.24);
tightening torque $M_A = 11 \text{ Nm } [8.2 \text{ ft-lbs}] \pm 15\%$,
(friction coefficient $\mu_{\text{total}} = 0.12$ to 0.17);
tightening torque $M_A = 8 \text{ Nm } [5.9 \text{ ft-lbs}] \pm 10\%$,
material no. **R978802879**

²⁾ Not included in the Rexroth delivery range

Circuit breakers with tripping characteristic "K"

according to EN 60898-1 (VDE 0641-11), EN 60947-2 (VDE 0660-101), IEC 60898 and IEC 60947-2

AC solenoid	Lower rated current <i>I</i> ₁ in A	Upper rated current <i>I</i> ₂ in A
50 Hz		
W24	2.30	3.60
W42	1.45	1.92
W48	1.15	1.92
W100	0.64	0.90
W110	0.60	0.90
W115	0.52	0.90
W127	0.48	0.60
W200	0.33	0.60
W220	0.31	0.60
W230	0.26	0.36
W240	0.26	0.36

AC solenoid	Lower rated current <i>I</i> ₁ in A	Upper rated current <i>I</i> ₂ in A
50 Hz		
W24	1.73	2.40
W42	1.13	1.92
W48	1.09	1.92
W100	0.58	0.90
W110	0.52	0.90
W115	0.43	0.90
W127	0.37	0.60
W200	0.30	0.60
W220	0.26	0.36
W230	0.20	0.36
W240	0.22	0.36

More information

- ▶ Subplates
- ▶ Inductive position switch and proximity sensors (contactless)
- ▶ Smoothly switching version
- ▶ Mineral oil-based hydraulic fluids
- ▶ Reliability characteristics according to EN ISO 13849
- ▶ General product information on hydraulic products
- ▶ Installation, commissioning and maintenance of industrial valves
- ▶ Hydraulic valves for industrial applications
- ▶ Selection of the filters

Data sheet 45052

Data sheet 24830

Data sheet 23183

Data sheet 90220

Data sheet 08012

Data sheet 07008

Data sheet 07300

Data sheet 07600-B

www.boschrexroth.com/filter

Notes

Bosch Rexroth AG
Hydraulics
Zum Eisengießer 1
97816 Lohr am Main, Germany
Phone +49 (0) 93 52/ 18-0
documentation@boschrexroth.de
www.boschrexroth.de

© This document, as well as the data, specifications and other information set forth in it, are the exclusive property of Bosch Rexroth AG. It may not be reproduced or given to third parties without its consent.
The data specified above only serve to describe the product. No statements concerning a certain condition or suitability for a certain application can be derived from our information. The information given does not release the user from the obligation of own judgment and verification. It must be remembered that our products are subject to a natural process of wear and aging.