

# CE/EMC TEST REPORT

For  
Renqiu Jinyi Electrical Equipment Co., Ltd.

Product Name : Diesel air heater

Trademark : N/A

Model Number : 5000W-12  
5000W-24,2000W-12,2000W-24,3000W-12,3000W-24,  
4,8000W-12,8000W-24

Prepared For : Renqiu Jinyi Electrical Equipment Co., Ltd.

Address : North Of Chenzhuang Village,Lvgongbao  
Town,Renqiu City

Report No. : LST190678012ER

Testing laboratory : Shenzhen LST Technology Co., Ltd.

Address : Huichao Building, Yintian Industry zone, Bao'an  
District, Shenzhen, Guangdong P.R. China

## TABLE OF CONTENT

	Page
Test Report Declaration	5
<b>1. GENERAL INFORMATION</b>	<b>5</b>
1.1. Description of Device (EUT)	5
1.2. Tested System Details	5
1.3. Test Uncertainty	5
1.4. Test Facility	5
<b>2. TEST INSTRUMENT USED</b>	<b>6</b>
<b>3. CONDUCTED EMISSION AT THE MAINS TERMINALS TEST</b>	<b>7</b>
3.1. Block Diagram Of Test Setup	7
3.2. Test Standard	7
3.3. Power Line Conducted Emission Limit	7
3.4. EUT Configuration on Test	7
3.5. Operating Condition of EUT	7
3.6. Test Procedure	8
3.7. Test Result	8
<b>4. RADIATION EMISSION TEST</b>	<b>10</b>
4.1. Block Diagram of Test Setup	11
4.2. Test Standard	11
4.3. Radiation Limit	11
4.4. EUT Configuration on Test	12
4.5. Operating Condition of EUT	12
4.6. Test Procedure	12
4.7. Test Result	12
<b>5. HARMONIC CURRENT EMISSION TEST</b>	<b>15</b>
5.1. Block Diagram of Test Setup	15
5.2. Test Standard	15
5.3. Operating Condition of EUT	15
5.4. Test Procedure	15
5.5. Test Results	15
<b>6. VOLTAGE FLUCTUATIONS &amp; FLICKER TEST</b>	<b>16</b>
6.1. Block Diagram of Test Setup	16
6.2. Test Standard	16
6.3. Operating Condition of EUT	16
6.4. Test Procedure	16
6.5. Test Results	16
<b>7. ELECTROSTATIC DISCHARGE IMMUNITY TEST</b>	<b>17</b>
7.1. Block Diagram of Test Setup	17
7.2. Test Standard	17
7.3. Severity Levels and Performance Criterion	17
7.4. EUT Configuration	18
7.5. Operating Condition of EUT	18
7.6. Test Procedure	18
7.7. Test Results	19
<b>8. RF FIELD STRENGTH SUSCEPTIBILITY TEST</b>	<b>20</b>
8.1. Block Diagram of Test Setup	20
8.2. Test Standard	20
8.3. Severity Levels and Performance Criterion	21
8.4. EUT Configuration on Test	21
8.5. Operating Condition of EUT	21

8.6.	Test Procedure .....	22
8.7.	Test Results.....	22
<b>9.</b>	<b>ELECTRICAL FAST TRANSIENT/BURST IMMUNITY TEST.....</b>	<b>23</b>
9.1.	Block Diagram of EUT Test Setup .....	23
9.2.	Test Standard.....	23
9.3.	Severity Levels and Performance Criterion.....	23
9.4.	EUT Configuration on Test.....	24
9.5.	Operating Condition of EUT .....	24
9.6.	Test Procedure .....	24
9.7.	Test Results.....	24
<b>10.</b>	<b>SURGE TEST .....</b>	<b>25</b>
10.1.	Block Diagram of EUT Test Setup .....	25
10.2.	Test Standard.....	25
10.3.	Severity Levels and Performance Criterion.....	25
10.4.	EUT Configuration on Test.....	26
10.5.	Operating Condition of EUT .....	26
10.6.	Test Procedure .....	26
10.7.	Test Result.....	26
<b>11.</b>	<b>INJECTED CURRENTS SUSCEPTIBILITY TEST .....</b>	<b>27</b>
11.1.	Block Diagram of EUT Test Setup .....	27
11.2.	Test Standard.....	27
11.3.	Severity Levels and Performance Criterion.....	27
11.4.	EUT Configuration on Test.....	28
11.5.	Operating Condition of EUT .....	28
11.6.	Test Procedure .....	28
11.7.	Test Result.....	28
<b>12.</b>	<b>VOLTAGE DIPS AND INTERRUPTIONS TEST .....</b>	<b>29</b>
12.1.	Block Diagram of EUT Test Setup .....	29
12.2.	Test Standard.....	29
12.3.	Severity Levels and Performance Criterion.....	29
12.4.	EUT Configuration on Test.....	30
12.5.	Operating Condition of EUT .....	30
12.6.	Test Procedure .....	30
12.7.	Test Result.....	30
<b>13.</b>	<b>EUT PHOTOGRAPHS .....</b>	<b>31</b>

**Shenzhen LST Testing Co., Ltd.**

Applicant : Renqiu Jinyi Electrical Equipment Co., Ltd.  
Address : North Of Chenzhuang Village,Lvgongbao Town,Renqiu City  
Manufacturer : Renqiu Jinyi Electrical Equipment Co., Ltd.  
Address : North Of Chenzhuang Village,Lvgongbao Town,Renqiu City  
EUT : Diesel air heater  
Model Number : 5000W-12  
Trademark: : N/A  
Test Date : Jun. 06, 2019– Jun. 11, 2019  
Date of Report : Jun. 11, 2019  
**Test Result:** : The equipment under test was found to be compliance with the requirements of the standards applied.

## Test Procedure Used:

EMI : EN 55014-1:2017  
EN 61000-3-2:2014, EN 61000-3-3:2013  
EMS : EN 55014-2:2015  
EN 61000-4-2:2009, EN 61000-4-3:2006+A1:2008+A2:2010,  
EN 61000-4-4:2012, EN 61000-4-5:2014,  
EN 61000-4-6:2014, EN 61000-4-11:2004

Prepared by(Engineer):



Reviewer(Supervisor):



Approved(Manager):



This test report is based on a single evaluation of one sample of above mentioned products. The test results in the report only apply to the tested sample. It is not permitted to be duplicated in extracts without written approval of Shenzhen LST Technology Co., Ltd.

## 1. GENERAL INFORMATION

### 1.1. Description of Device (EUT)

EUT : Diesel air heater  
Trademark : N/A  
Model Number : 5000W-12  
Power Supply : DC12V, 5KW

### 1.2. Tested System Details

None.

### 1.3. Test Uncertainty

Conducted Emission  
Uncertainty :  $\pm 2.66$ dB

Radiated Emission Uncertainty :  $\pm 4.26$ dB

### 1.4. Test Facility

Site Description :

Name of Firm : Shenzhen LST Technology Co., Ltd.

Address : Huichao Building, Yintian Industry zone, Bao'an  
District, Shenzhen, Guangdong P.R. China

## 2.TEST INSTRUMENT USED

### For Conducted Emission at the mains terminals Test

Conducted Emission Test ( A --- site )					
Equipment	Manufacturer	Model#	Serial#	Last Cal.	Next Cal.
843 Shielded Room	ChengYu	843 Room	843	Aug. 25, 2018	Aug. 24, 2019
EMI Receiver	R&S	ESCI	101421	Aug. 27, 2018	Aug. 26, 2019
LISN	SCHWARZB ECK	NSLK8127	812779	Sep. 07, 2018	Sep. 06, 2019
Pulse Limiter	R&S	ESH3-Z2	100681	Aug. 25, 2018	Aug. 24, 2019
843 Cable 1#	FUJIKURA	843C1#	001	Aug. 25, 2018	Aug. 24, 2019

### For Radiated Emission Test

Radiation Emission Test (966 chamber)					
Equipment	Manufacturer	Model#	Serial#	Last Cal.	Next Cal.
966 chamber	ChengYu	966 Room	966	Aug. 25, 2018	Aug. 24, 2019
Spectrum Analyzer	Agilent	E4407B	MY45109572	Aug. 27, 2018	Aug. 26, 2019
Amplifier	Schwarzbeck	BBV9743	9743-119	Aug. 25, 2018	Aug. 24, 2019
Amplifier	Schwarzbeck	BBV9718	9718-270	Aug. 25, 2018	Aug. 24, 2019
Log-periodic Antenna	Schwarzbeck	VULB9160	VULB9160-3 369	Sep. 07, 2018	Sep. 06, 2019
EMI Receiver	R&S	ESCI	101421	Aug. 27, 2018	Aug. 26, 2019
Horn Antenna	Schwarzbeck	BBHA9120D	9120D-1275	Aug. 25, 2018	Aug. 24, 2019
966 Cable 1#	CHENGYU	966	004	Aug. 25, 2018	Aug. 24, 2019
966 Cable 2#	CHENGYU	966	003	Aug. 25, 2018	Aug. 24, 2019

### For Electrostatic Discharge Immunity Test

For Electrostatic Discharge Immunity Test ( A --- site )					
Equipment	Manufacturer	Model#	Serial#	Last Cal.	Next Cal.
ESD Tester	KIKISUI	KES4201A	UH002321	Aug. 28, 2018	Aug. 27, 2019

### 3.CONDUCTED EMISSION AT THE MAINS TERMINALS TEST

#### 3.1.Block Diagram Of Test Setup

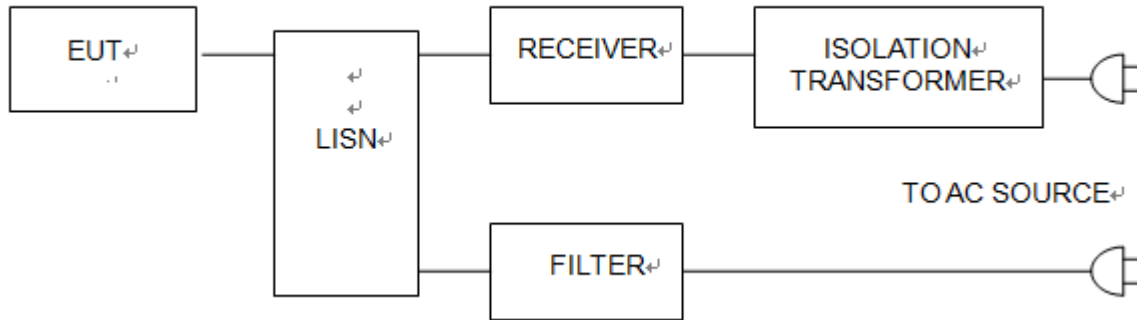

#### 3.2.Test Standard

EN 55014-1:2017

#### 3.3.Power Line Conducted Emission Limit

Frequency MHz	Limits dB(μV)	
	Quasi-peak Level	Average Level
0.15 ~ 0.50	66 ~ 56*	56 ~ 46*
0.50 ~ 5.00	56	46
5.00 ~ 30.00	60	50

Notes: 1. \*Decreasing linearly with logarithm of frequency.

2. The lower limit shall apply at the transition frequencies.

#### 3.4.EUT Configuration on Test

The following equipments are installed on conducted emission test to meet EN 55014-1 requirement and operating in a manner which tends to maximize its emission characteristics in a normal application.

#### 3.5.Operating Condition of EUT

3.5.1 Setup the EUT and simulators as shown in Section 3.1.

3.5.2 Turn on the power of all equipments.

3.5.3 Let the EUT work in test modes and test it.

### 3.6. Test Procedure

The EUT is put on the ground and connected to the AC mains through a Artificial Mains Network (AMN). This provided a 50ohm coupling impedance for the tested equipments. Both sides of AC line are checked to find out the maximum conducted emission levels according to the **EN 55014-1** regulations during conducted emission test.

The bandwidth of the test receiver (R&S Test Receiver ESCI) is set at 10KHz.

The frequency range from 150 KHz to 30 MHz is investigated.

### 3.7. Test Result

**PASS**

Please refer to the following page.



Conducted Emission At The Telecom Port Test Data			
Temperature:	24.5 °C	Relative Humidity:	54%
Pressure:	1009hPa	Phase :	Line
Test Voltage :	DC 12V	Test Mode:	On Mode

### Conducted Emission Measurement

File :3

Data :#1

90.0 dBuV

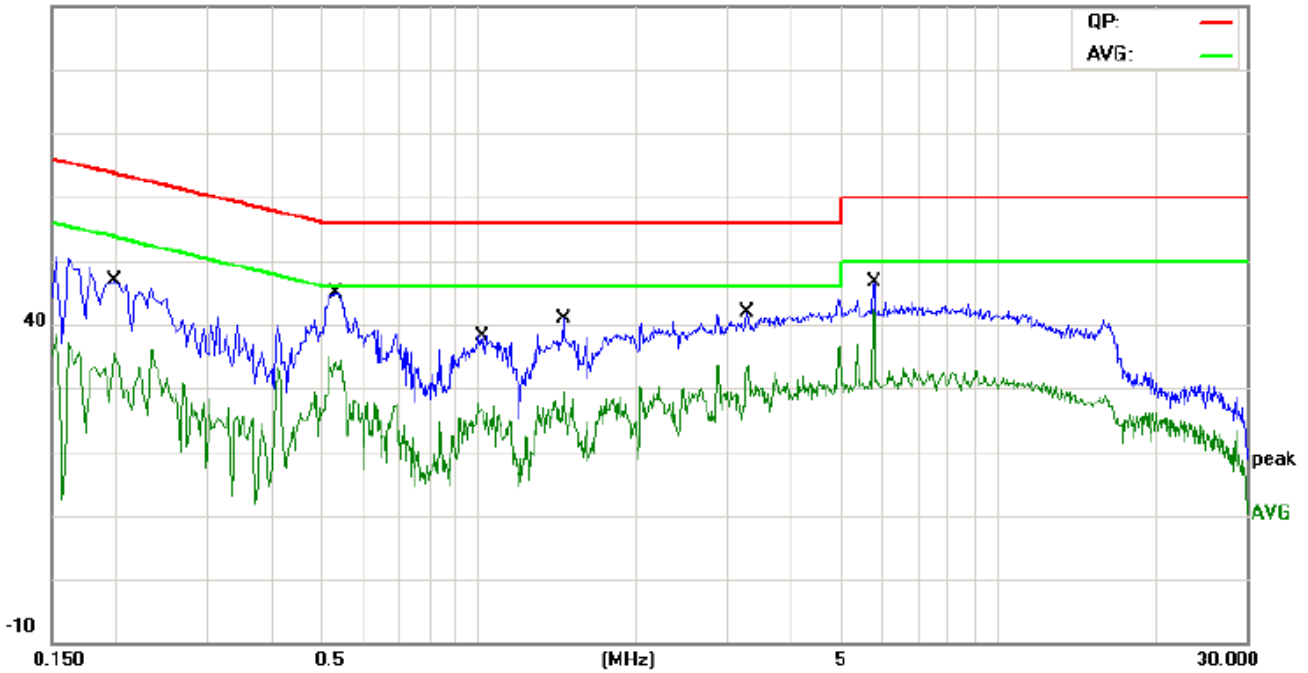

No.	Mk.	Freq.	Reading Level	Correct Factor	Measurement	Limit	Over	Detector	Comment
		MHz	dBuV	dB	dBuV	dBuV	dB		
1		0.1980	32.60	9.58	42.18	63.69	-21.51	QP	
2		0.1980	19.21	9.58	28.79	53.69	-24.90	AVG	
3	*	0.5299	33.61	9.60	43.21	56.00	-12.79	QP	
4		0.5299	23.33	9.60	32.93	46.00	-13.07	AVG	
5		1.0180	26.29	9.60	35.89	56.00	-20.11	QP	
6		1.0180	15.81	9.60	25.41	46.00	-20.59	AVG	
7		1.4540	26.93	9.60	36.53	56.00	-19.47	QP	
8		1.4540	18.96	9.60	28.56	46.00	-17.44	AVG	
9		3.2780	27.01	9.65	36.66	56.00	-19.34	QP	
10		3.2780	19.38	9.65	29.03	46.00	-16.97	AVG	
11		5.7619	28.81	9.79	38.60	60.00	-21.40	QP	
12		5.7619	20.10	9.79	29.89	50.00	-20.11	AVG	

\*:Maximum data    x:Over limit    !:over margin

## Conducted Emission At The Telecom Port Test Data

Temperature:	24.5 °C	Relative Humidity:	54%
Pressure:	1009hPa	Phase :	Neutral
Test Voltage :	DC12V	Test Mode:	On Mode

### Conducted Emission Measurement

File :3

Data :#2

90.0 dBuV



No.	Mk.	Freq. MHz	Reading Level dBuV	Correct Factor dB	Measure- ment dBuV	Limit dBuV	C dB	Detector	Comment
1		0.1539	35.64	9.64	45.28	65.78	-20.50	QP	
2		0.1539	23.95	9.64	33.59	55.78	-22.19	AVG	
3		0.2260	30.23	9.63	39.86	62.59	-22.73	QP	
4		0.2260	20.13	9.63	29.76	52.59	-22.83	AVG	
5	*	0.5340	33.38	9.58	42.96	56.00	-13.04	QP	
6		0.5340	23.06	9.58	32.64	46.00	-13.36	AVG	
7		1.0180	26.43	9.59	36.02	56.00	-19.98	QP	
8		1.0180	15.73	9.59	25.32	46.00	-20.68	AVG	
9		3.2540	26.52	9.68	36.20	56.00	-19.80	QP	
10		3.2540	17.12	9.68	26.80	46.00	-19.20	AVG	
11		5.7220	28.78	10.05	38.83	60.00	-21.17	QP	
12		5.7220	20.00	10.05	30.05	50.00	-19.95	AVG	

\*:Maximum data    x:Over limit    !:over margin

## 4.RADIATION EMISSION TEST

### 4.1.Block Diagram of Test Setup

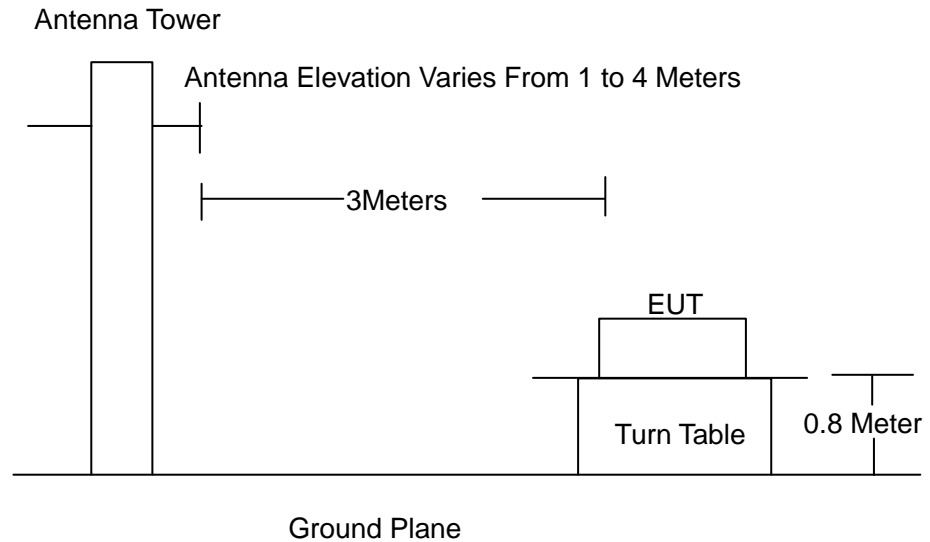

### 4.2.Test Standard

EN 55014-1:2017

### 4.3.Radiation Limit

Frequency MHz	Distance (Meters)	Field Strengths Limits dB(μV)/m
30 ~ 230	3	40.0
230 ~ 1000	3	47.0

Remark:

- (1) Emission level (dB(μV)/m) = 20 log Emission level (μV/m)
- (2) The smaller limit shall apply at the cross point between two frequency bands.
- (3) Distance refers to the distance in meters between the measuring instrument, antenna and the closed point of any part of the device or system.

#### 4.4.EUT Configuration on Test

The EN 55014-1 regulations test method must be used to find the maximum emission during radiated emission test.

The configuration of EUT is the same as used in conducted emission test. Please refer to Section 2.2.

#### 4.5.Operating Condition of EUT

Same as conducted emission test, which is listed in Section 2.2 except the test set up replaced as Section 4.1.

#### 4.6.Test Procedure

The EUT and its simulators are placed on a turned table that is 0.8 meter above the ground. The turned table can rotate 360 degrees to determine the position of the maximum emission level. The EUT is set 3 meters away from the receiving antenna that is mounted on the antenna tower. The antenna can move up and down between 1 meter and 4 meters to find out the maximum emission level. Broadband antenna (calibrated biconical and log periodical antenna) is used as receiving antenna. Both horizontal and vertical polarization of the antenna is set on test. In order to find the maximum emission levels, the interface cable must be manipulated according to EN 55014-1 on radiated emission test.

The bandwidth setting on the field strength meter (R&S Test Receiver ESCI) is set at 120KHz.

The frequency range from 30MHz to 1000MHz is checked.

#### 4.7.Test Result

**PASS**

Please refer to the following page.

Radiation Emission Test Data			
Temperature:	24.5 °C	Relative Humidity:	54%
Pressure:	1009hPa	Phase :	Horizontal
Test Voltage :	DC 12V	Test Mode:	On Mode

### Radiated Emission Measurement

File :3

Data :#33

80.0 dBuV/m

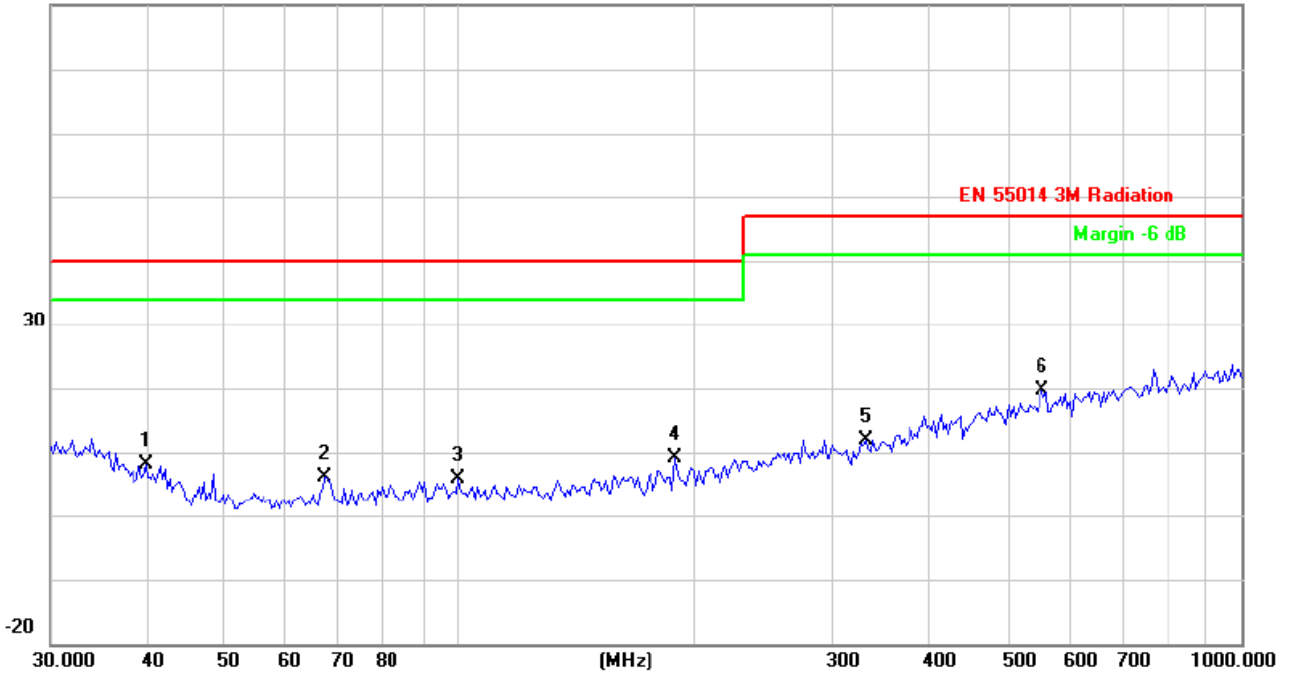

No.	Mk.	Freq.	Reading Level	Correct Factor	Measurement	Limit	Over	Antenna Height	Table Degree	
		MHz	dBuV	dB/m	dBuV/m	dBuV/m	dB	cm	degree	Comment
1		39.7146	27.08	-18.97	8.11	40.00	-31.89	peak		
2		67.2022	29.82	-23.74	6.08	40.00	-33.92	peak		
3		99.5281	27.98	-22.09	5.89	40.00	-34.11	peak		
4		188.4125	28.96	-19.88	9.08	40.00	-30.92	peak		
5		330.1949	27.17	-15.22	11.95	47.00	-35.05	peak		
6	*	554.8254	28.61	-9.06	19.55	47.00	-27.45	peak		

\*:Maximum data    x:Over limit    !:over margin

Radiation Emission Test Data			
Temperature:	24.5 °C	Relative Humidity:	54%
Pressure:	1009hPa	Phase :	Vertical
Test Voltage :	DC 12V	Test Mode:	On Mode

### Radiated Emission Measurement

File :3

Data :#34

80.0 dBuV/m

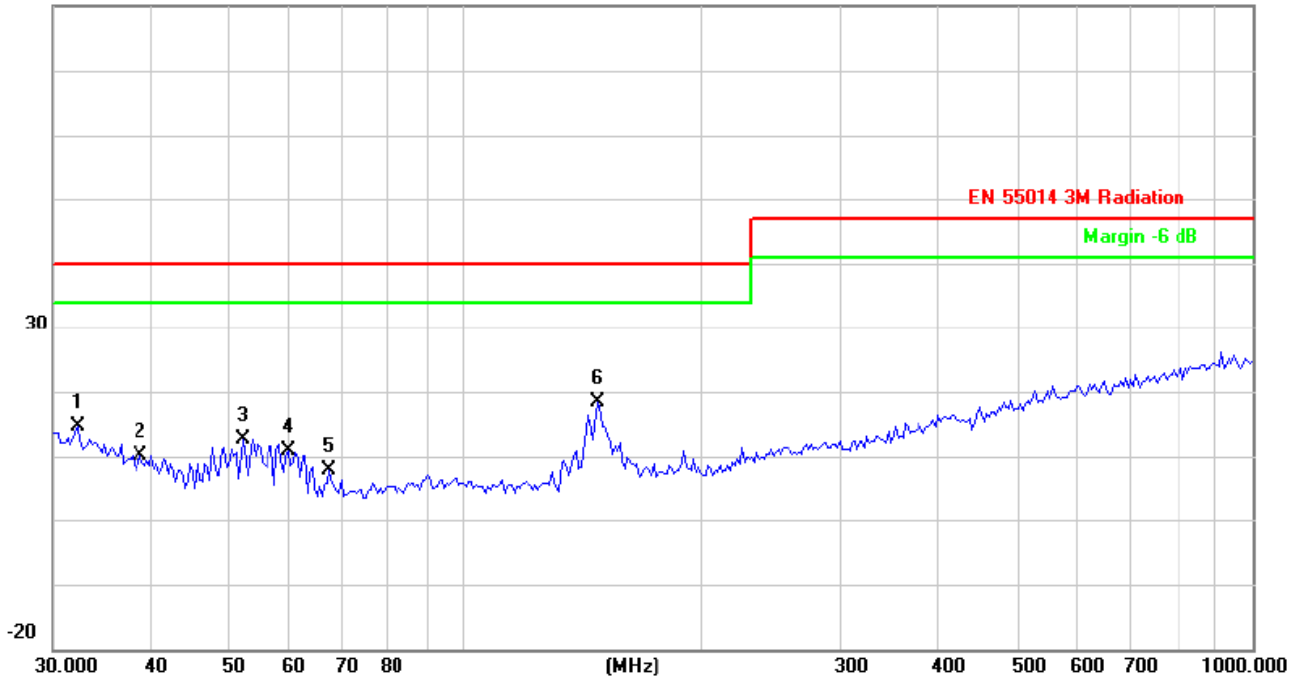

No.	Mk.	Freq.	Reading Level	Correct Factor	Measurement	Limit	Over	Antenna Height	Table Degree	
		MHz	dBuV	dB/m	dBuV/m	dBuV/m	dB	cm	degree	Comment
1		32.1795	29.16	-14.64	14.52	40.00	-25.48			peak
2		38.6160	28.67	-18.46	10.21	40.00	-29.79			peak
3		52.2079	36.15	-23.49	12.66	40.00	-27.34			peak
4		59.6493	35.10	-24.32	10.78	40.00	-29.22			peak
5		67.2022	31.57	-23.74	7.83	40.00	-32.17			peak
6	*	147.4036	40.01	-21.71	18.30	40.00	-21.70			peak

\*:Maximum data    x:Over limit    !:over margin

## 5.HARMONIC CURRENT EMISSION TEST

### 5.1. Block Diagram of Test Setup

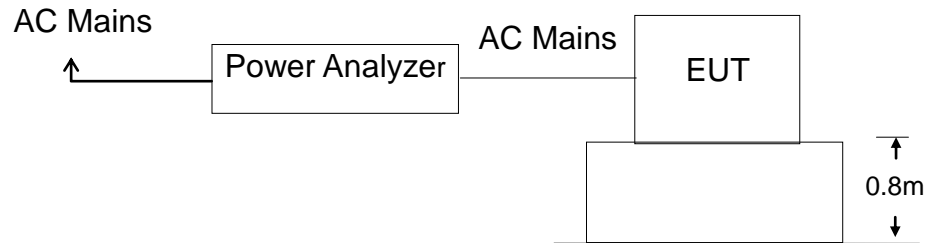

### 5.2. Test Standard

EN 61000-3-2:2014

### 5.3. Operating Condition of EUT

- 5.3.1 Setup the EUT as shown in Section 5.1.
- 5.3.2 Turn on the power of all equipments.
- 5.3.3 Let the EUT work in test mode and test it.

### 5.4. Test Procedure

The power cord of the EUT is connected to the output of the test system. Turn on the power of the EUT and use the test system to test the harmonic current level.

### 5.5. Test Results

The EUT is powered by the DC only, the test item is not applicable.

## 6.VOLTAGE FLUCTUATIONS & FLICKER TEST

### 6.1.Block Diagram of Test Setup

Same as Section 6.1..

### 6.2.Test Standard

EN 61000-3-3:2013

### 6.3.Operating Condition of EUT

Same as Section 5.3.. The power cord of the EUT is connected to the output of the test system. Turn on the power of the EUT and use the test system to test the harmonic current level.

#### Flicker Test Limit

Test items	Limits
Pst	1.0
dc	3.3%
Tmax	4.0%
dt	Not exceed 3.3% for 500ms

### 6.4. Test Procedure

The power cord of the EUT is connected to the output of the test system. Turn on the power of the EUT and use the test system to test the harmonic current level.

### 6.5.Test Results

The EUT is powered by the DC only, the test item is not applicable.



## 7.ELECTROSTATIC DISCHARGE IMMUNITY TEST

### 7.1.Block Diagram of Test Setup

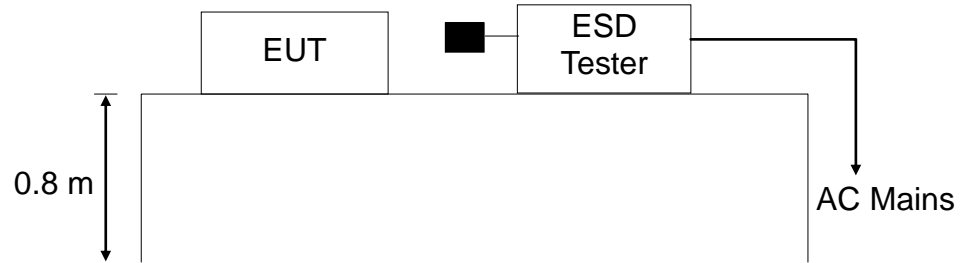

### 7.2.Test Standard

EN 55014-2:2015:, EN 61000-4-2:2009

Severity Level: 3 / Air Discharge:±8KV

Level: 2 / Contact Discharge:±4KV

### 7.3.Severity Levels and Performance Criterion

#### 7.3.1 Severity level

Level	Test Voltage Contact Discharge (KV)	Test Voltage Air Discharge (KV)
1.	±2	±2
2.	±4	±4
3.	±6	±8
4.	±8	±15
X	Special	Special

#### 7.3.2 Performance criterion : B

- A.** The apparatus shall continue to operate as intended during the test. No degradation of performance or loss of function is allowed below a performance level (or permissible loss of performance) specified by the manufacturer, when the apparatus is used as i

- B.** The apparatus shall continue to operate as intended after the test. No degradation of performance or loss of function is allowed below a performance level (or permissible loss of performance) specified by the manufacturer, when the apparatus is used as intended. During the test, degradation of performance is allowed, however, no change of actual operating state or stored data is allowed. If the minimum performance level or the permissible performance loss is not specified by the manufacturer, then either of these may be derived from the product description and documentation, and from what the user may reasonably expect from the apparatus if used as intended.
  
- C.** Temporary loss of function is allowed, provided the function is self-recoverable or can be restored by the operation of the controls, or by any operation specified in the instructions for use.

#### 7.4.EUT Configuration

The following equipments are installed on Electrostatic Discharge Immunity test to meet EN 55014-2:2015:, EN 61000-4-2:2009, requirement and operating in a manner which tends to maximize its emission characteristics in a normal application. The configuration of EUT is the same as used in conducted emission test.

Please refer to Section 2.4.

#### 7.5.Operating Condition of EUT

Same as conducted emission measurement, which is listed in Section 3.5 except the test setup replaced by Section 7.1.2.

#### 7.6.Test Procedure

##### 7.6.1 Air Discharge:

This test is done on a non-conductive surface. The round discharge tip of the discharge electrode shall be approached as fast as possible to touch the EUT. After each discharge, the discharge electrode shall be removed from the EUT. The generator is then re-triggered for a new single discharge and repeated 10 times for each pre-selected test point. This procedure shall be repeated until all the air discharge completed.

##### 7.6.2 Contact Discharge:

All the procedure shall be same as Section 7.6.1. Except that the tip of the discharge electrode shall touch the EUT before the discharge switch is operated.

##### 7.6.3 Indirect discharge for horizontal coupling plane

At least 10 single discharges (in the most sensitive polarity) shall be applied at the front edge of each HCP opposite the center point of each unit (if applicable) of the EUT and 0.1m from the front of the EUT. The long axis of

the discharge electrode shall be in the plane of the HCP and perpendicular to its front edge during the discharge.

7.6.4 Indirect discharge for vertical coupling plane

At least 10 single discharges (in the most sensitive polarity) shall be applied to the center of one vertical edge of the coupling plane. The coupling plane, of dimensions 0.5m X 0.5m, is placed parallel to, and positioned at a distance of 0.1m from the EUT. Discharges shall be applied to the coupling plane, with this plane in sufficient different positions that the four faces of the EUT are complete illuminated.

7.7. Test Results

**PASS**

Please refer to the following page.

ESD Test Data				
Temperature:	24.5°C	Humidity:	53%	
Power Supply :	DC 12V	Test Mode:	Discharge	
Air Discharge: ± 8KV				
Contact Discharge: ± 4KV				
Test Points	Air Discharge	Contact Discharge	Performance Criterion	Result
Enclosure	±2,4,8KV	N/A	B	PASS
Slit	±2,4,8KV	N/A	B	PASS
Metal Part	N/A	±2,4 KV	B	PASS
VCP	N/A	±2,4 KV	B	PASS
HCP	N/A	±2,4 KV	B	PASS
Note: N/A				

## 8. RF FIELD STRENGTH SUSCEPTIBILITY TEST

### 8.1. Block Diagram of Test Setup

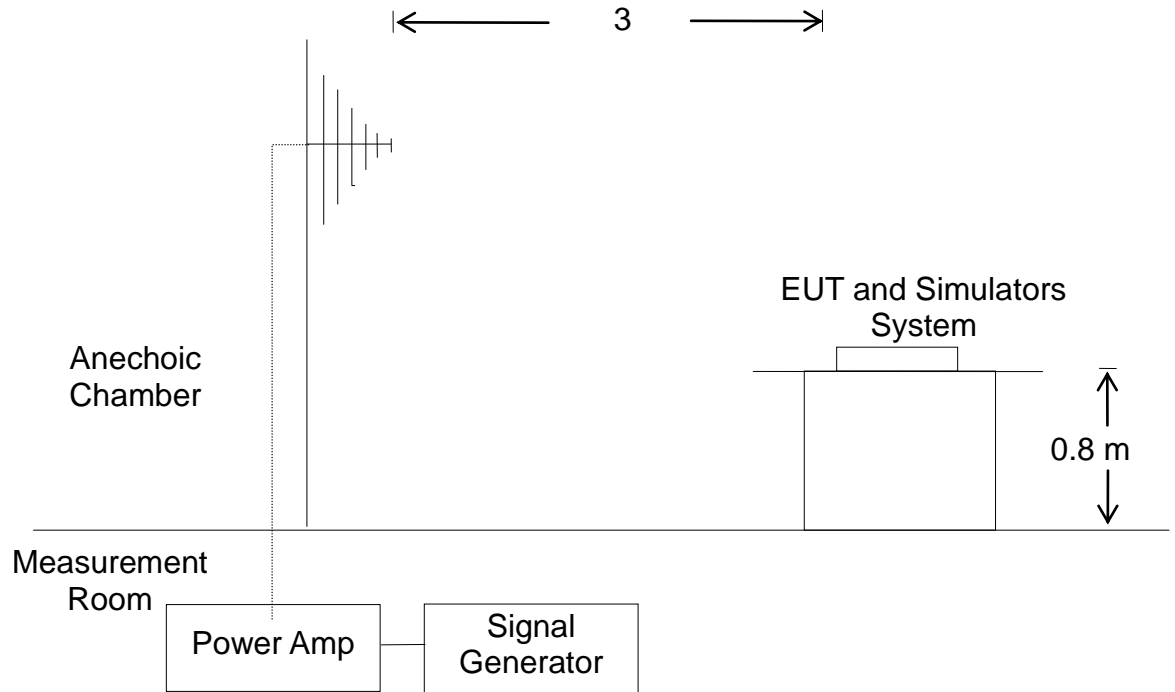

### 8.2. Test Standard

EN 55014-2:2015,  
EN 61000-4-3: 2006+A1:2008+A2:2010

Severity Level 2, 3V / m

## 8.3. Severity Levels and Performance Criterion

### 8.3.1. Severity level

Level	Field Strength V/m
1.	1
2.	3
3.	10
X.	Special

### 8.3.2. Performance criterion: A

- A、 The apparatus shall continue to operate as intended during the test. No degradation of performance or loss of function is allowed below a performance level (or permissible loss of performance) specified by the manufacturer, when the apparatus is used as i
- B、 The apparatus shall continue to operate as intended after the test. No degradation of performance or loss of function is allowed below a performance level (or permissible loss of performance) specified by the manufacturer, when the apparatus is used as intended. During the test, degradation of performance is allowed, however, no change of actual operating state or stored data is allowed. If the minimum performance level or the permissible performance loss is not specified by the manufacturer, then either of these may be derived from the product description and documentation, and from what the user may reasonably expect from the apparatus if used as intended.
- C、 Temporary loss of function is allowed, provided the function is self-recoverable or can be restored by the operation of the controls, or by any operation specified in the instructions for use.

## 8.4. EUT Configuration on Test

The following equipments are installed on RF FIELD STRENGTH SUSCEPTIBILITY TEST to meet EN 55014-2:2015, EN 61000-4-3: 2006+A1:2008+A2:2010, requirement and operating in a manner which tends to maximize its emission characteristics in a normal application. The configuration of EUT is the same as used in conducted emission test.

Please refer to Section 3.4.

## 8.5. Operating Condition of EUT

Same as conducted emission measurement, which is listed in Section 2.5 except the test setup replaced by Section 8.1.

### 8.6. Test Procedure

The EUT and its simulators are placed on a turn table which is 0.8 meter above ground. EUT is set 3 meter away from the transmitting antenna which is mounted on an antenna tower. Both horizontal and vertical polarization of the antenna are set on test. Each of the four sides of EUT must be faced this transmitting antenna and measured individually.

All the scanning conditions are as follows :

Condition of Test	Remarks
1. Fielded Strength	3 V/m (Severity Level 2)
2. Radiated Signal	Modulated
3. Scanning Frequency	80 – 1000 MHz
4. Dwell time of radiated	0.0015 decade/s
5. Waiting Time	1 Sec.

### 8.7. Test Results

**PASS**

Please refer to the following page.

R/S Test Data			
Temperature : 25°C		Humidity : 53%	
Field Strength: 3 V/m		Criterion: A	
Power Supply: DC 12V		Frequency Range: 80 MHz to 1000 MHz	
Modulation: <input checked="" type="checkbox"/> AM <input type="checkbox"/> Pulse <input type="checkbox"/> none    1 KHz    80%			
Test Mode : Discharge			
Frequency Range : 80-1000MHz			
Steps	1 %		
	Horizontal	Vertical	Result
Front	A	A	Pass
Right	A	A	Pass
Rear	A	A	Pass
Left	A	A	Pass
Note: N/A			

## 9.ELECTRICAL FAST TRANSIENT/BURST IMMUNITY TEST

### 9.1.Block Diagram of EUT Test Setup

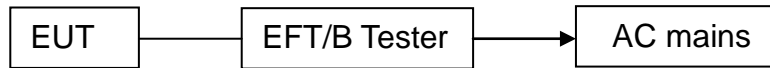

### 9.2.Test Standard

EN 55014-2:2015.; EN 61000-4-4:2012

### 9.3.Severity Levels and Performance Criterion

Severity Level 2 at 1KV, Pulse Rise time & Duration: 5 nS / 50 nS

Severity Level:

Open Circuit Output Test Voltage $\pm 10\%$		
Level	On power ports	On I/O(Input/Output) Signal data and control ports
1.	0.5KV	0.25KV
2.	1KV	0.5KV
3.	2KV	1KV
4.	4KV	2KV
X.	Special	Special

#### Performance criterion: B

- A. The apparatus shall continue to operate as intended during the test. No degradation of performance or loss of function is allowed below a performance level (or permissible loss of performance) specified by the manufacturer, when the apparatus is used as i
- B. The apparatus shall continue to operate as intended after the test. No degradation of performance or loss of function is allowed below a performance level (or permissible loss of performance) specified by the manufacturer, when the apparatus is used as intended. During the test, degradation of performance is allowed, however, no change of actual operating state or stored data is allowed. If the minimum performance level or the permissible performance loss is not specified by the manufacturer, then either of these may be derived from the product description and documentation, and from what the user may reasonably expect from the apparatus if used as intended.
- C. Temporary loss of function is allowed, provided the function is self-recoverable or can be restored by the operation of the controls, or by any operation specified in the instructions for use.

#### 9.4.EUT Configuration on Test

The following equipments are installed on Electrical Fast Transient/Burst Immunity test to meet EN 55014-2:2015., EN 61000-4-4:2012, requirement and operating in a manner which tends to maximize its emission characteristics in a normal application. The configuration of EUT is the same as used in conducted emission test.

Please refer to Section 3.4.

#### 9.5.Operating Condition of EUT

Same as conducted emission measurement, which is listed in Section 2.6 except the test setup replaced by Section 9.1.

#### 9.6.Test Procedure

EUT shall be placed 0.8m high above the ground reference plane which is a min.1m\*1m metallic sheet with 0.65mm minimum thickness. This reference ground plane shall project beyond the EUT by at least 0.1m on all sides and the minimum distance between EUT and all other conductive structure, except the ground plane beneath the EUT, shall be more than 0.5m

9.6.1. For input and output AC power ports:

The EUT is connected to the power mains by using a coupling device which couples the EFT interference signal to AC power lines. Both polarities of the test voltage should be applied during compliance test and the duration of the test is 2 minutes.

#### 9.7.Test Results

The EUT is powered by the DC only, the test item is not applicable.



## 10.SURGE TEST

### 10.1. Block Diagram of EUT Test Setup

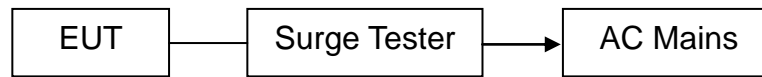

### 10.2. Test Standard

EN 55014-2:2015., EN61000-4-5:2014

### 10.3. Severity Levels and Performance Criterion

Severity Level: Line to Line, Level 2 at 1KV;

Severity Level: Line to Earth, Level 3 at 2KV.

Severity Level	Open-Circuit Test Voltage (KV)
1.	0.5
2.	1.0
3.	2.0
4.	4.0
X.	Special

#### Performance criterion: B

- A. The apparatus shall continue to operate as intended during the test. No degradation of performance or loss of function is allowed below a performance level (or permissible loss of performance) specified by the manufacturer, when the apparatus is used as i
- B. The apparatus shall continue to operate as intended after the test. No degradation of performance or loss of function is allowed below a performance level (or permissible loss of performance) specified by the manufacturer, when the apparatus is used as intended. During the test, degradation of performance is allowed, however, no change of actual operating state or stored data is allowed. If the minimum performance level or the permissible performance loss is not specified by the manufacturer, then either of these may be derived from the product description and documentation, and from what the user may reasonably expect from the apparatus if used as intended.
- C. Temporary loss of function is allowed, provided the function is self-recoverable or can be restored by the operation of the controls, or by any operation specified in the instructions for use.

#### 10.4. EUT Configuration on Test

The following equipments are installed on Electrical Fast Transient/Burst Immunity test to meet EN 55014-2:2015:, EN61000-4-5:2014, requirement and operating in a manner which tends to maximize its emission characteristics in a normal application

The configuration of EUT is the same as used in conducted emission test. Please refer to Section 3.4.

#### 10.5. Operating Condition of EUT

Same as conducted emission measurement, which is listed in Section 2.7 except the test setup replaced by Section 10.1.

#### 10.6. Test Procedure

- 1) Set up the EUT and test generator as shown on section 10.1
- 2) For line to line coupling mode, provide a 1KV 1.2/50us voltage surge (at open-circuit condition) and 8/20us current surge to EUT selected points.
- 3) At least 5 positive and 5 negative (polarity) tests with a maximum 1/min repetition rate are conducted during test.
- 4) Different phase angles are done individually.
- 5) Repeat procedure 2) to 4) except the open-circuit test voltage change from 1KV to 2KV for line to earth coupling mode test.
- 6) Record the EUT operating situation during compliance test and decide the EUT immunity criterion for above each test.

#### 10.7. Test Result

The EUT is powered by the DC only, the test item is not applicable.

## 11.INJECTED CURRENTS SUSCEPTIBILITY TEST

### 11.1. Block Diagram of EUT Test Setup

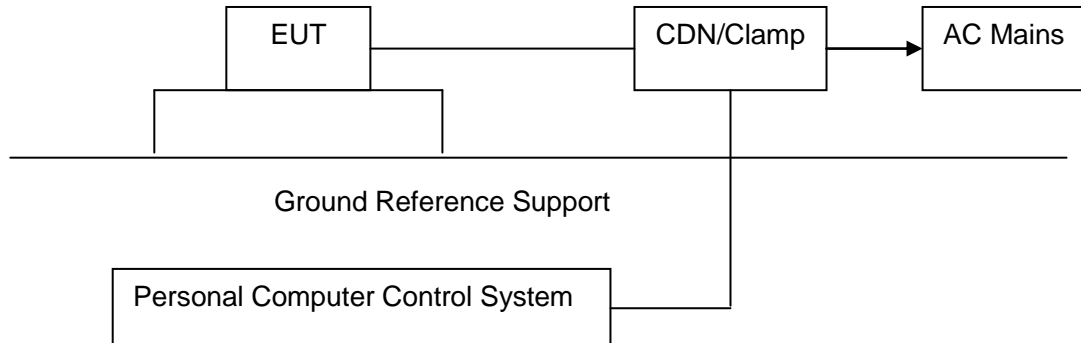

### 11.2. Test Standard

EN 55014-2:2015., EN61000-4-6:2014

### 11.3. Severity Levels and Performance Criterion

Severity Level 2: 3V( rms ), 150KHz ~ 80MHz

Severity Level:

Level	Field Strength V
1.	1
2.	3
3.	10
X.	Special

#### Performance criterion: A

- A. The apparatus shall continue to operate as intended during the test. No degradation of performance or loss of function is allowed below a performance level (or permissible loss of performance) specified by the manufacturer, when the apparatus is used as i
- B. The apparatus shall continue to operate as intended after the test. No degradation of performance or loss of function is allowed below a performance level (or permissible loss of performance) specified by the manufacturer, when the apparatus is used as intended. During the test, degradation of performance is allowed, however, no change of actual operating state or stored data is allowed. If the minimum performance level or the permissible performance loss is not specified by the manufacturer, then either of these may be derived from the product description and documentation, and from what the user may reasonably expect from the apparatus if used as intended.

- C. Temporary loss of function is allowed, provided the function is self-recoverable or can be restored by the operation of the controls, or by any operation specified in the instructions for use.

#### 11.4. EUT Configuration on Test

The configuration of EUT is the same as used in conducted emission test. Please refer to Section 2.8.

#### 11.5. Operating Condition of EUT

Same as conducted emission test, which is listed in Section 2.8 except the test set up replaced as Section 11.1.

#### 11.6. Test Procedure

- 1) Set up the EUT, CDN and test generator as shown on section 11.1
- 2) Let EUT work in test mode and measure.
- 3) The EUT and supporting equipments are placed on an insulating support 0.1m high above a ground reference plane. CDN (coupling and decoupling device) is placed on the ground plane at above 0.1-0.3m from EUT. Cables between CDN and EUT are as short as possible, and their height above the ground reference plane shall be between 30 and 50 mm (where possible).
- 4) The disturbance signal described below is injected to EUT through CDN.
- 5) The EUT operates within its operational mode(s) under intended climatic conditions after power on.
- 6) The frequency range is swept from 150KHz to 80MHz using 3V signal level, and with the disturbance signal 80% amplitude modulated with a 1KHz sine wave
- 7) The rate of sweep shall not exceed  $1.5 \times 10^{-3}$  decades/s. Where the frequency is swept incrementally, the step size shall not exceed 1% of the start and thereafter 1% of the preceding frequency value.
- 8) Recording the EUT operating situation during compliance test and decide the EUT immunity criterion for above each test.

#### 11.7. Test Result

The EUT is powered by the DC only, the test item is not applicable.

## 12.VOLTAGE DIPS AND INTERRUPTIONS TEST

### 12.1. Block Diagram of EUT Test Setup



### 12.2. Test Standard

EN 55014-2:2015:, EN61000-4-11:2004

### 12.3. Severity Levels and Performance Criterion

Severity Level:

Input and Output AC Power Ports.

- Voltage Dips.
- Voltage Interruptions.

Environmental Phenomena	Test Specification	Units	Performance Criterion
Voltage Dips	70	% Reduction period	C
	25		
	40	% Reduction period	C
10			
Voltage Interruptions	0 0.5	% Reduction period	C

**Performance criterion: B, C, C**

- A. The apparatus shall continue to operate as intended during the test. No degradation of performance or loss of function is allowed below a performance level (or permissible loss of performance) specified by the manufacturer, when the apparatus is used as i
- B. The apparatus shall continue to operate as intended after the test. No degradation of performance or loss of function is allowed below a performance level (or permissible loss of performance) specified by the manufacturer, when the apparatus is used as intended. During the test, degradation of performance is allowed, however, no change of actual operating state or stored data is allowed. If the minimum performance level or the permissible performance loss is not specified by the manufacturer, then either of these may be derived from the product description and documentation, and from what the user may reasonably expect from the apparatus if used as intended.

- C. Temporary loss of function is allowed, provided the function is self-recoverable or can be restored by the operation of the controls, or by any operation specified in the instructions for use.

#### 12.4. EUT Configuration on Test

The configuration of EUT is the same as used in conducted emission test. Please refer to Section 2.10.

#### 12.5. Operating Condition of EUT

Same as conducted emission test, which is listed in Section 2.10 except the test set up replaced as Section 13.1.

#### 12.6. Test Procedure

- 1) Set up the EUT and test generator as shown on section 13.1
- 2) The interruption is introduced at selected phase angles with specified duration. There is a 3mins minimum interval between each test event.
- 3) After each test a full functional check is performed before the next test.
- 4) Repeat procedures 2 & 3 for voltage dips, only the level and duration is changed.
- 5) Record any degradation of performance.

#### 12.7. Test Result

The EUT is powered by the DC only, the test item is not applicable.

## 13.EUT PHOTOGRAPHS

EUT Photo 1

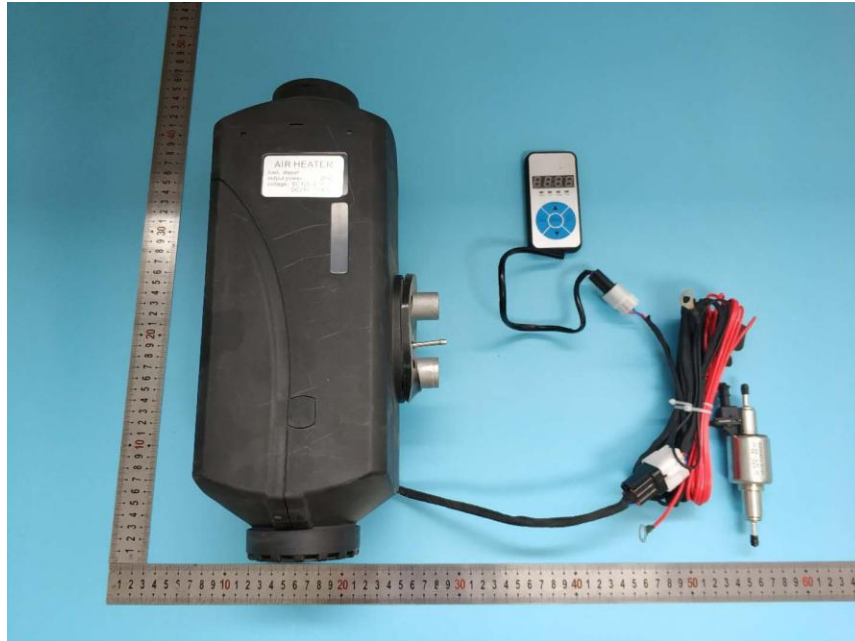

EUT Photo 2



EUT Photo 3



EUT Photo 4





EUT Photo 5



EUT Photo 6

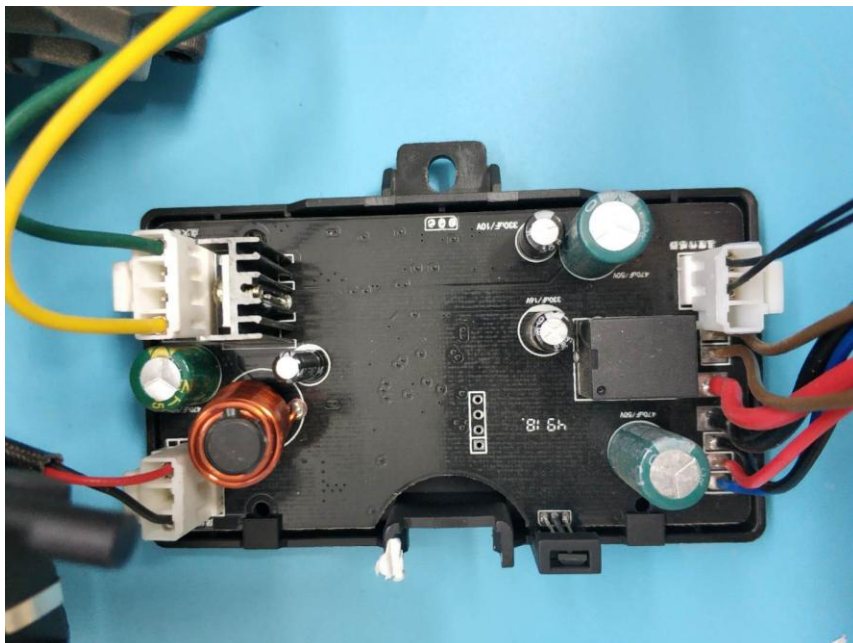

\*\*\*\*\* END OF REPORT \*\*\*\*\*