

ZBIORNIK BUFOROWY / BUFFER TANK / BUFFERHALTER

Calma Mini

50, 80, 100 - bez węzownicy / without coils / ohne wärmetauschen



 **5 LAT GWARANCJI**

Calma Mini	50	80	100
Maksymalna temp. pracy		90°C	
Minimalna temp. pracy		6°C	
Maksymalne ciśnienie pracy		6 bar	
Klasa energetyczna		C	
Waga	17 kg	17 kg	30 kg

ZBIORNIK BUFOROWY / BUFFER TANK / BUFFERHALTER

Calma Mini

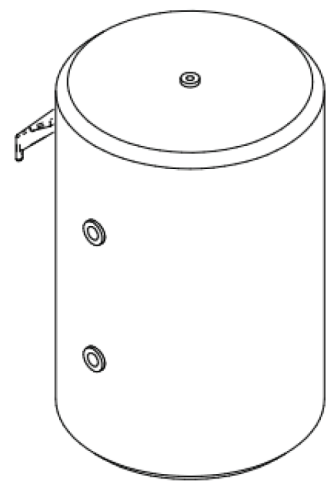
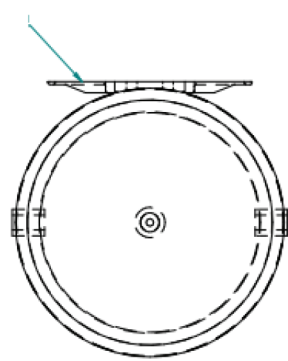
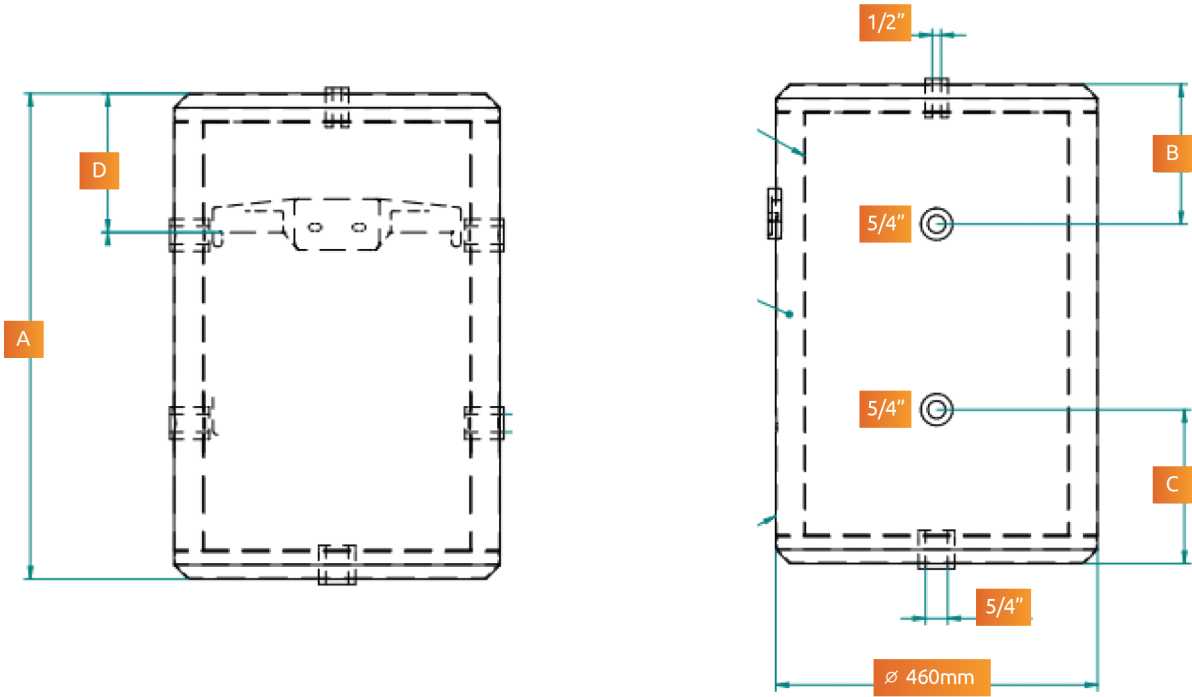

	A (mm)	B (mm)	C (mm)	D (mm)
Calma Mini 50	600	240	185	180
Calma Mini 80	760	240	240	180
Calma Mini 100	960	240	240	180

Tolerancja wymiarów / dimensional tolerance / masstoleranzen = [±/5mm]