

Markiza

INSTRUKCJA OBSŁUGI

Side awning

USER MANUAL

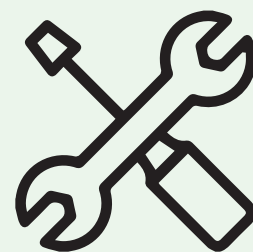
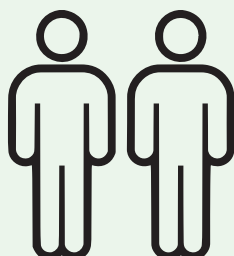

Instruction manual

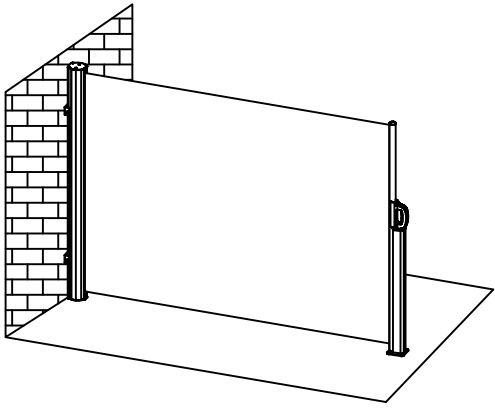

Parts list

<01>				
<02>		M6×60		x4
				x4
		M10×50		x4
<03>		M8×75		x4
				x4
		M12×50		x4

Assembly tool

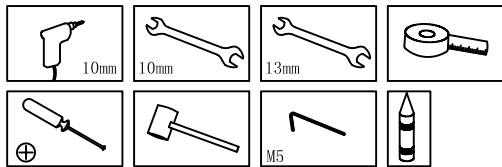

! NOTICE:

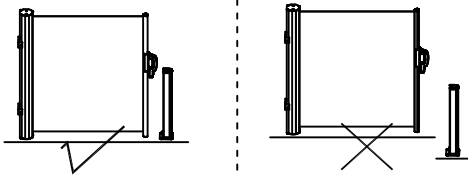

I

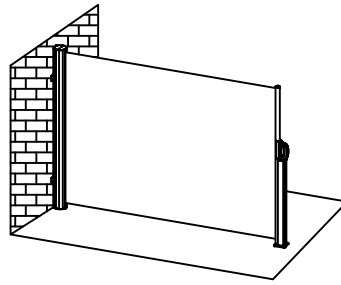

Parts list

<01>				
<02>		M6×60		x4
				x4
		M10×50		x4
<03>		M8×75		x4
				x4
		M12×50		x4

Assembly tool

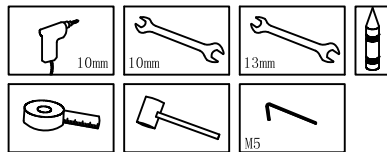

01	<01>		x1
	<02>		x2

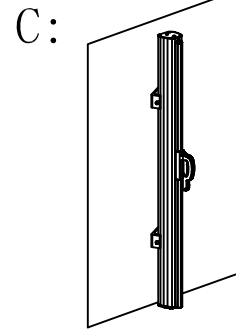
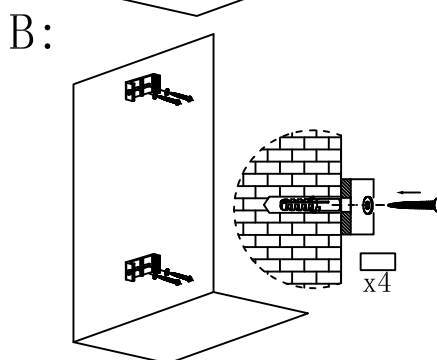
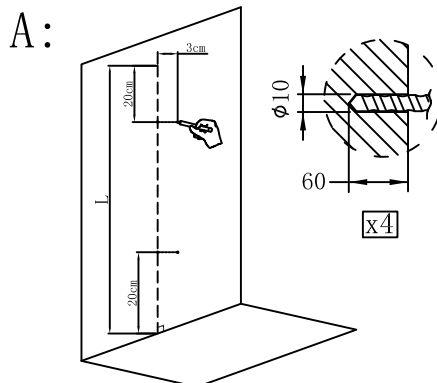

02	<03>		x1
-----------	------	--	----

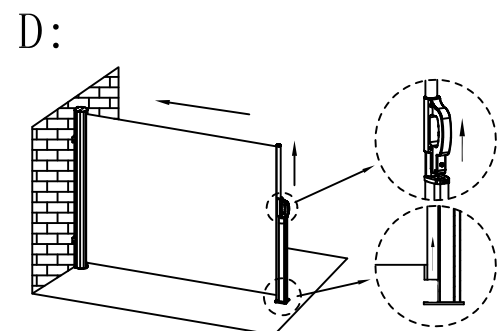
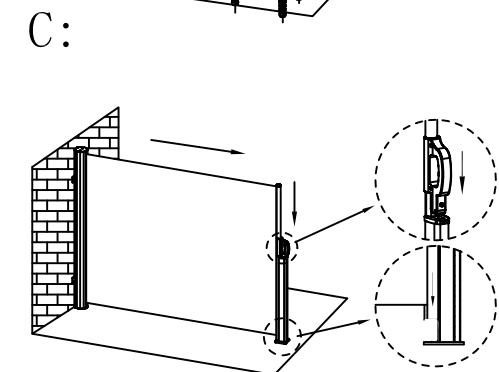
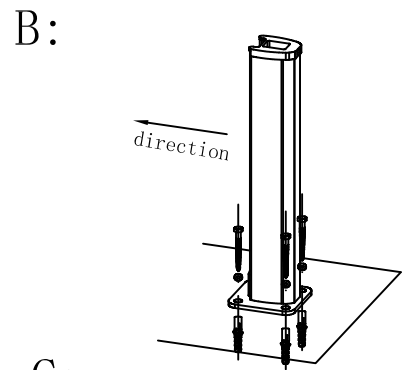
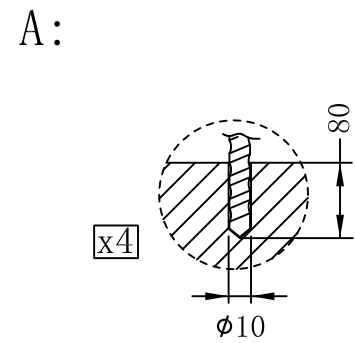

Wszystkie tkaniny zostały zabezpieczone impregnatem. Czynniki atmosferyczne takie jak kwaśny deszcz lub zanieczyszczenia pochodzenia zwierzęcego oraz stosowanie środków chemicznych do czyszczenia tkanin mogą uszkodzić warstwę ochronną.

All fabrics have been treated with waterproofing. Atmospheric agents such as acid rain or animal pollutants and the use of fabric cleaning chemicals can damage the protective layer.

Konserwacja: Maintenance:



Zanieczyszczenia należy usunąć poprzez delikatne szczotkowanie, lub odkurzanie tkaniny.
Remove dirt by gently brushing, or vacuuming the fabric.

30°

Do usuwania trudnych zanieczyszczeń można użyć wody z mydłem o temperaturze maksymalnie 30°C, następnie należy dokładnie spłukać tkaninę.
Soapy water with a maximum temperature of 30°C can be used to remove tough dirt, then rinse the fabric thoroughly.



Markiza przed zwinięciem powinna zostać dokładnie wysuszona.
The awning should be thoroughly dried before being rolled up.



Nie używać rozpuszczalników ani mocnych detergentów, które mogą uszkodzić powłokę ochronną.
Do not use solvents or strong detergents that can damage the protection coating.



Nie prać poszycia markizy.
Do not wash the awning cover.

Zaleca się przeprowadzanie konserwacji co najmniej dwa razy w roku – przed i po sezonie. W tym celu konieczne jest smarowanie wszystkich ruchomych elementów markizy, zaleca się używanie teflonu w sprayu.

It is recommended to carry out maintenance at least twice a year - before and after the season. To do this, it is necessary to lubricate all moving parts of the awning, it is recommended to use Teflon spray.

